

---

# SafeSeaNet System Interface Guide

---



**Location Data  
exchange**

---

*Document version: 1.14*

*Document release date: 13/09/2019*

*SSN\_LocationData\_Exchange compliant with XSD version: 1.27*

*XSD release date: 16/07/2019*

---

## TABLE OF CONTENTS

<b>TABLE OF CONTENTS .....</b>	<b>2</b>
<b>CHANGE CONTROL HISTORY .....</b>	<b>3</b>
<b>ABBREVIATIONS AND ACRONYMS .....</b>	<b>4</b>
<b>1 INTRODUCTION .....</b>	<b>5</b>
1.1 DOCUMENT OVERVIEW .....	5
1.2 SCOPE .....	5
1.3 APPLICABLE CLD RELEASE.....	5
<b>2 SYSTEM INTERFACES .....</b>	<b>6</b>
2.1 SERVICES OVERVIEW.....	6
2.2 MESSAGE FLOWS.....	6
2.2.1 <i>Request/ Response</i> .....	6
2.2.2 <i>Announcement</i> .....	7
2.2.3 <i>Notification</i> .....	9
2.3 DATA EXCHANGE MECHANISM - CLARIFICATIONS .....	10
2.3.1 <i>Data Provider Interface</i> .....	10
2.3.2 <i>Data Requestor Interface</i> .....	11
2.3.3 <i>Data Subscriber Interface</i> .....	11
<b>3 MESSAGES STRUCTURES AND BUSINESS RULES .....</b>	<b>12</b>
3.1 REQUEST/RESPONSE MECHANISM .....	12
3.1.1 <i>Introduction</i> .....	12
3.1.2 <i>Message flow</i> .....	12
3.1.3 <i>MS2SSN_Location_Req message</i> .....	12
3.1.4 <i>SSN2MS_Location_Res message</i> .....	14
3.2 GET LOCATION LOGS FROM CLD .....	19
3.2.1 <i>Introduction</i> .....	19
3.2.2 <i>Message flow</i> .....	19
3.2.3 <i>MS2SSN_LocationLog_Req message</i> .....	19
3.2.4 <i>SSN2MS_LocationLog_Res message</i> .....	21
3.3 ANNOUNCEMENT MECHANISM.....	24
3.3.1 <i>Introduction</i> .....	24
3.3.2 <i>Message flow</i> .....	24
3.3.3 <i>MS2SSN_LocationAnn_Req message</i> .....	25
3.3.4 <i>SSN2MS_LocationAnn_Res message</i> .....	27
3.4 NOTIFICATION MECHANISM .....	34
3.4.1 <i>Introduction</i> .....	34
3.4.2 <i>Message flow</i> .....	34
3.4.3 <i>MS2SSN_Location_Not message</i> .....	35
3.5 SSN RECEIPT MESSAGE .....	38
3.5.1 <i>Introduction</i> .....	38
3.5.2 <i>Message flow</i> .....	38
3.5.3 <i>SSN_Receipt.xml message</i> .....	38
3.6 STATUS CODES AND STATUS MESSAGES .....	39
3.6.1 <i>Introduction</i> .....	39
3.6.2 <i>Status codes</i> .....	39
3.6.3 <i>Status messages</i> .....	40
<b>ANNEX A - DESCRIPTION OF CLD LOCATION WEB-SERVICE .....</b>	<b>41</b>

**ANNEX B – ATTRIBUTES AND SIMPLE TYPE DEFINITIONS..... 42**  
**ANNEX C– LIST OF APPLICATION CODES (INDICATIVE) ..... 53**

**CHANGE CONTROL HISTORY**

Version	Date	Edited by	Description
1.03	07/12/2017	LZI, PDU	Initial version following EMSA review.
1.05	25/09/2018	Intrasoft International	Updated version following delivery of CLD version 1.0.0.1 including correction of defects reported under SAT for CLD version 1.0 (artf54537, artf54540, artf54859, artf54544, artf54535, artf54539, artf54533) and implementation of requirements: <ul style="list-style-type: none"> <li>• COD shall use the CLD web service for searching locations based on the location name and/or country (artf53593).</li> <li>• Add criterion to search by location name in CLD web service (artf53598).</li> <li>• Remove 500 records limit for the responses provided as zipped base 64 file (artf53599)</li> </ul>
1.06	31/10/2018	Intrasoft International	Updated SSN_Location_Exchange XSD version following delivery of CLD version 1.0.0.2 – Incorporated business rule for: <ul style="list-style-type: none"> <li>• MS2SSN_LocationAnn_Req message: “A valid Body shall define the SearchCriteria or the CancelSubscription element”.</li> </ul>
1.07	05/12/2018	Intrasoft International	Updated for CLD version 1.0.1. Updated description of messages exchange pattern.  artf56477: FunctionsUNECE Type with INT instead of CHAR
1.08	21/01/2019	Intrasoft International	Updated for  artf57767: ReplyTo wsa field and WSA Addressing to be removed; migration from SOAP 1.1 to SOAP 1.2  artf57885: Removal of ESRefId and SSNRefId from the header
1.09	01/02/2019	Intrasoft International	EMSA changes checked / confirmed.

1.12	16/07/2019	Intrasoft International	Request for Services SC13 under FWC 15/EMSA/OP/18/2015: DDP Locations and Port Facilities support and improvements to the Textual interface (COD&CLD 1.2)
1.13	26/07/2019	Intrasoft International	EMSA comments implemented
1.14	13/09/2019	Intrasoft International	EMSA comments implemented

### **ABBREVIATIONS AND ACRONYMS**

<b>Abbreviation</b>	<b>Definition</b>
ACK	Acknowledged
AIS	Automatic Identification Systems
CLD	Central Location Database of SSN
EMSA	European Maritime Safety Agency
ES	External System
MS2SSN	Used to indicate an External System as the origin and SSN as the recipient of a message.
EU	European Union
GISIS	Global Integrated Shipping Information System (database maintained by IMO)
IMO	International Maritime Organisation
ITU	International Telecommunications Commission
MMSI	Maritime Mobile Service Identity
MS	Member State
N/A	Not Applicable or Not Available
NACK	Not Acknowledged
OSD	Operational Ship Database
SSN	SafeSeaNet
SSN2MS	Used to indicate SSN as the origin and an External System as the recipient of a message.
URL	Unified Resource Locator
WADL	<a href="#">Web Application Description Language</a> . It describes XML over HTTP interfaces
WSDL	Web Service Definition Language
XML	eXtensible Markup Language

---

# **1 INTRODUCTION**

---

## **1.1 Document Overview**

This document describes the system-to-system interface of the Central Location Database (CLD) of SafeSeaNet (SSN). It serves as a reference for all technical aspects related to this service.

## **1.2 Scope**

This document provides a detailed description of the system interface between external applications and CLD, which aims at exchanging notifications and requests for details concerning locations' information registered in CLD. The system interface uses the following messages:

- MS2SSN\_Location\_Not
- MS2SSN\_Location\_Req
- SSN2MS\_Location\_Res
- MS2SSN\_LocationAnn\_Req
- SSN2MS\_LocationAnn\_Res
- MS2SSN\_LocationLog\_Req
- SSN2MS\_LocationLog\_Res
- SSN\_Receipt

## **1.3 Applicable CLD release**

This document is compliant with CLD version 1.2.

## 2 SYSTEM INTERFACES

### 2.1 Services Overview

The Central Location Database – CLD is a common service hosted by EMSA and available to all Member State applications and other EMSA applications (identified in this document as “External Systems”) on a voluntary basis.

The CLD includes information on locations (including UNECE UN/LOCODEs as well as SSN specific locations) and on port facilities coming from the IMO GISIS.

The CLD information is made available to External Systems, which may use it for cross-checking with similar data stored within their databases. For this purpose, CLD offers the following services:

- **Request/response mechanism:** to request locations details using different criterions (e.g. country of the Location, name of the location). The request/ response mechanism can also be used for retrieving a journal of changes of individual location records.
- **Location data announcement ("push"):** This service is used by the CLD to inform External Systems which have subscribed to the service of creation of new Locations or changes of existing Locations.
- **Location notification:** External Systems may use this service to notify CLD of new locations or of updates of locations.

### 2.2 Message flows

#### 2.2.1 Request/ Response

The request/response mechanism for Location data involves the following flow of messages:

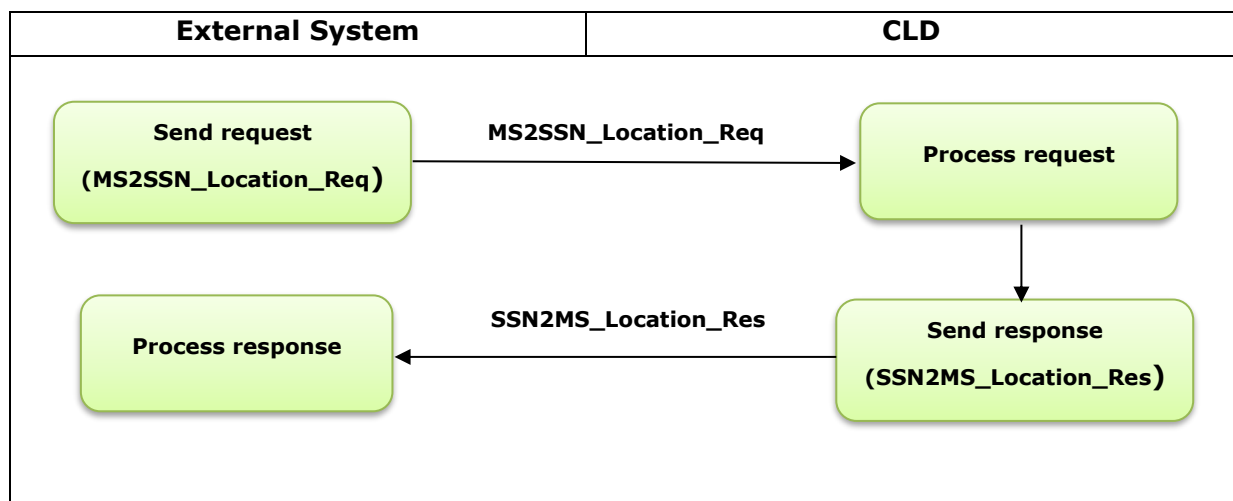

Figure 1: Message flow – Request / Response

It allows retrieving a list of location or a single location.

The process flow also applies to the **logs retrieval** service as depicted below.

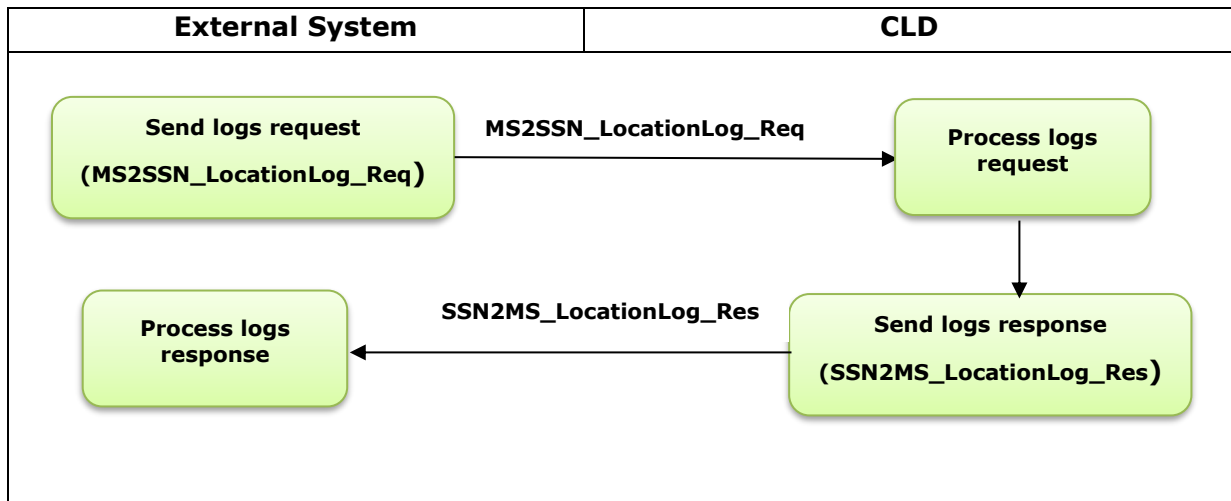

Figure 2: Message flow – Request/ Response for history of changes for a location in CLD

The message exchange flow is described in the following table.

Step	Action
1	The external system ( <i>data requestor</i> ) prepares a <b>MS2SSN_&lt;SSN_Tx_Type&gt;_Req</b> message corresponding to the type of the information request and sends it to CLD.
2	<p>CLD logs and validates the received <b>MS2SSN_&lt;SSN_Tx_Type&gt;_Req</b> message.</p> <p>In unexpected cases that <b>MS2SSN_&lt;SSN_Tx_Type&gt;_Req</b> message is not well-formatted (not XML compliant) or not valid (not compliant to corresponding XSD), CLD system responds with a SOAP Fault message.</p> <p>If valid based on applicable business rules, CLD prepares a <b>SSN2MS_&lt;SSN_Tx_Type&gt;_Res</b> response message and sends it synchronously. The content of the response will comply with the criteria set in the request message.</p> <p>If any problem occurs during the processing of the request, the CLD sends back (synchronously) the <b>SSN2MS_&lt;SSN_Tx_Type&gt;_Res</b> message with a negative status code.</p>
3	The external system should log and validate the received message and process it.

### 2.2.2 Announcement

The announcement mechanism involves a subscription request message flow and announcements message flow as follows:

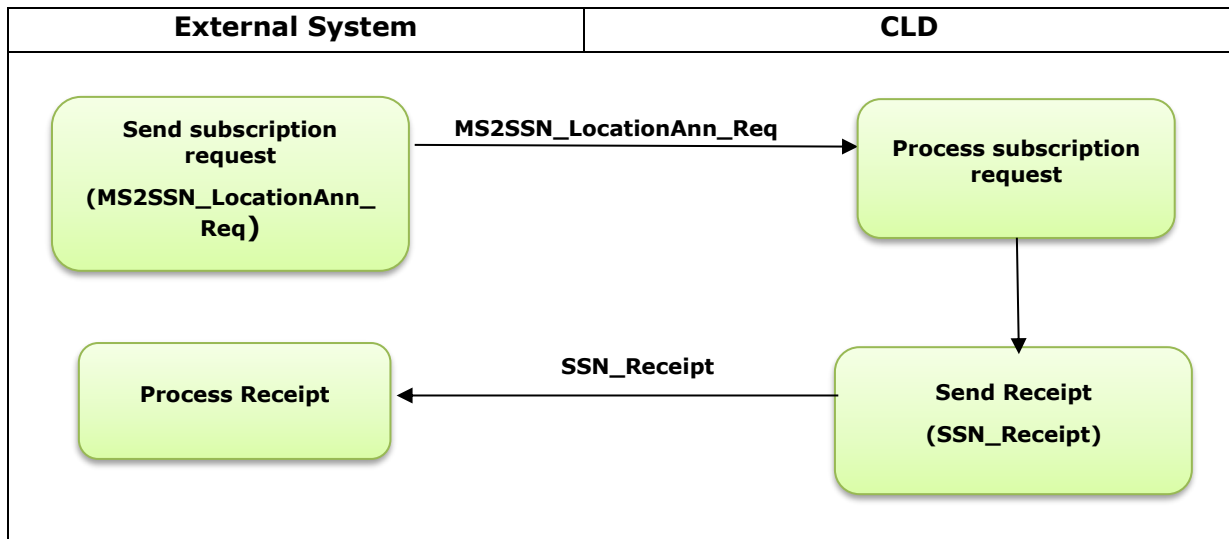

The message exchange flow is shown in the following table.

Step	Action
1	<p>A <b>MS2SSN_LocationAnn_Req</b> message is sent by the external system to CLD to</p> <ul style="list-style-type: none"> <li>➤ subscribe to the location announcement (data "push") service or</li> <li>➤ cancel an existing subscription.</li> </ul> <p>The message provides</p> <ul style="list-style-type: none"> <li>➤ the data subscriber URL to where the announcement is to be sent;</li> <li>➤ the optional parameters subscription's criteria and time period (start and end date).</li> </ul>
2	<p>Message processing:</p> <p>CLD logs and validates the received message.</p> <p>In unexpected cases that <b>MS2SSN_LocationAnn_Req</b> message is not well formatted (XML compliant) or not valid (not compliant to corresponding xsd), CLD system responds with a SOAP Fault message.</p> <p>If valid based on applicable business rules, an <b>SSN_Receipt</b> message with StatusCode='OK' is sent synchronously to the external system.</p> <p>If invalid based on applicable business rules, an <b>SSN_Receipt</b> message with StatusCode='InvalidFormat' is sent synchronously to the external system.</p> <p>If the system providing <b>MS2SSN_LocationAnn_Req</b> does not have CLD_SUBSCRIBER role or does not exist in the IdM V2, an <b>SSN_Receipt</b> message with StatusCode='Access Denied' is sent synchronously to the external system.</p>



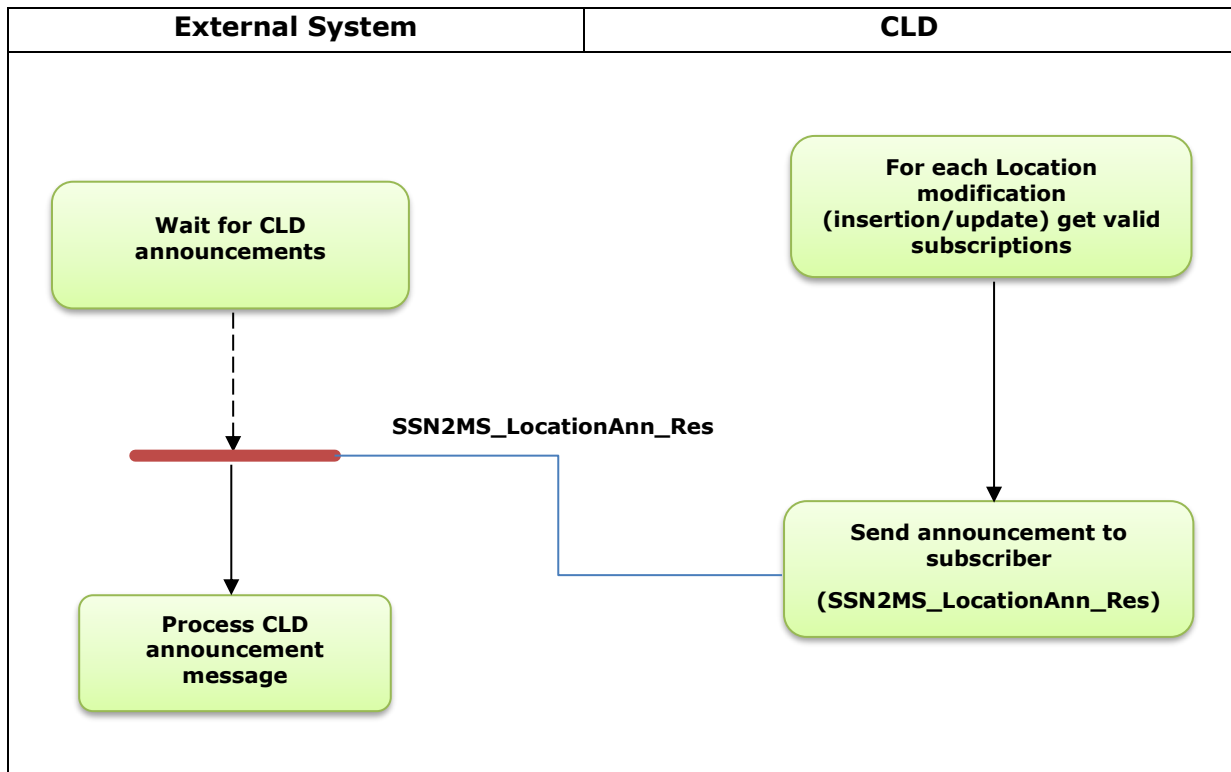

Figure 3: Message flows – Subscription for CLD data and CLD data announcement

The message exchange flow is shown in the following table.

Step	Action
1	The announcement creation procedure is triggered on locations modification (create/update) by system and/or web interface. In addition, CLD regularly checks the locations data for modifications via the bulk update procedure (inserts and updates). For each modification, the CLD will check and retrieve the valid subscriptions.
2	A <b>SSN2MS_LocationAnn_Res</b> message is created with the inserted or modified location information and submitted to the subscriptions endpoint - one-way messages without a SOAP response. The HTTP response MUST be a 2xx status code and an empty HTTP body, aka no SOAP envelope.
3	A JMS Queue is used for redelivery purposes in case of unavailability.
4	Upon receipt of the <b>SSN2MS_LocationAnn_Res</b> message, the external system should log and process it.

### 2.2.3 Notification

The Notification mechanism involves the following flow of messages:

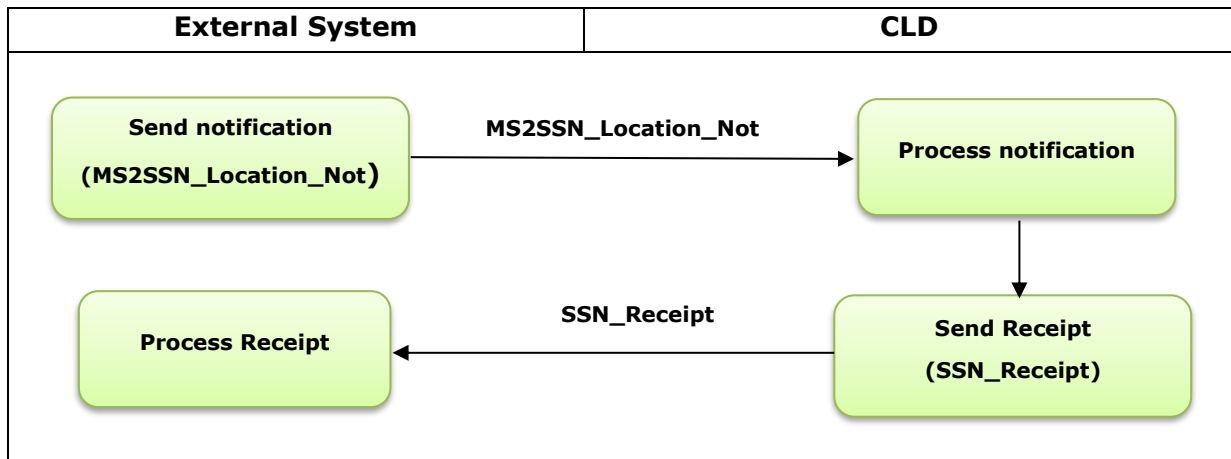

Figure 4: Message flows – Notification

The message exchange flow is shown in the following table.

Step	Action
1	The External System prepares an <b>MS2SSN_Location_Not</b> message which includes the information for a Location to be stored or updated in CLD.
2	CLD logs and validates the notification message: <ul style="list-style-type: none"> <li>• In unexpected cases that message is not well-formatted (not XML compliant) or not valid (not compliant to corresponding XSD), the CLD system responds with a SOAP Fault message.</li> <li>• If valid based on applicable business rules, it stores the notification information in its index database, and sends back a SSN_Receipt message with a positive status code as response (synchronous connection).</li> <li>• If invalid based on applicable business rules or any problem during the processing of the notification, it sends back a SSN_Receipt message with a negative status code as response (synchronous connection)</li> <li>• If system providing notification does not have CLD_NOTIFIER role or does not exist in the IdM V2, it sends back a SSN_Receipt message with access denied status code as response (synchronous connection)</li> </ul>
3	The External System analyses the received SSN_Receipt message and processes it accordingly.

## 2.3 Data exchange mechanism - clarifications

**Note:** This section aims at clarifying further the content of CLD wsdl provided in Appendix A.

### 2.3.1 Data Provider Interface

Both ends act as nodes capable of processing SOAP 1.2 messages (over HTTP/s). The message types used are as follows:

- **MS2SSN\_Location\_Not**
- **SSN\_Receipt**

---

For every notification, a request/response exchange pattern is used between each SOAP node where the SOAP response message is delivered as HTTP response, using the same connection as the inbound request.

### **2.3.2 Data Requestor Interface**

Both ends act as nodes capable of processing SOAP 1.2 messages (over HTTP/s). The message types used are as follows:

- **MS2SSN\_Location\_Req**
- **SSN2MS\_Location\_Res**
- **MS2SSN\_LocationLog\_Req**
- **SSN2MS\_LocationLog\_Res**

For every request–response communication, a request/response exchange pattern is used between each SOAP node where the SOAP response message is delivered as HTTP response, using the same connection as the inbound request.

### **2.3.3 Data Subscriber Interface**

Both ends act as nodes capable of processing SOAP 1.2 messages (over HTTP/s). The message types used are as follows:

- **MS2SSN\_LocationAnn\_Req**
- **SSN\_Receipt**, used for confirmation by CLD of the receipt and processing of the **MS2SSN\_LocationAnn\_Req** message
- **SSN2MS\_LocationAnn\_Res**

For subscription registration, the request/response exchange pattern is used between each SOAP node where the SOAP response message (SSN\_Receipt) is delivered as HTTP response, using the same connection as the inbound request.

The “Request Reply” interaction pattern is used for the subsequence of the announcements publishing. The subsequent message(s) (SSN2MS\_LocationAnn\_Res) sent from the destination of the registration request back to the source – i.e. one-way message connection is established to the subscriber SOAP node.

## 3 MESSAGES STRUCTURES AND BUSINESS RULES

### 3.1 Request/Response mechanism

#### 3.1.1 Introduction

The Request/Response mechanism is meant for External Systems to request the content of location records based on different criterions.

This section describes the different XML messages provided for this transaction.

#### 3.1.2 Message flow

The following figure outlines the expected synchronous flow of XML messages related to this transaction.

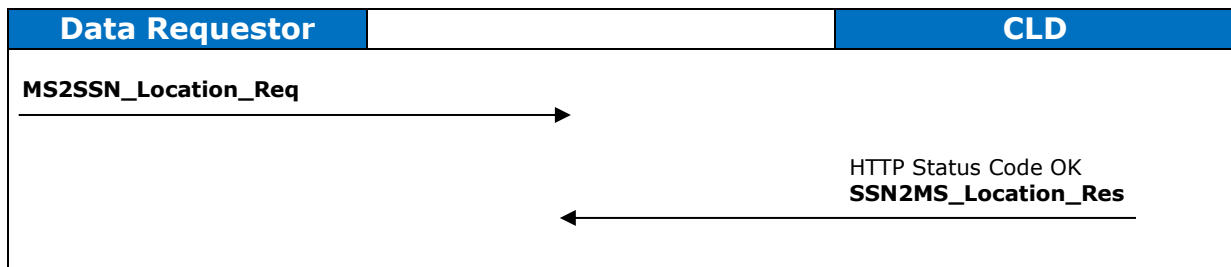

In accordance with the applicable wsdl (refer to Annex A), the request (QueryOperation) operation is provided by CLD. It receives **MS2SSN\_Location\_Req** requests from data requestors and replies with **SSN2MS\_Location\_Res** responses.

#### 3.1.3 MS2SSN\_Location\_Req message

The MS2SSN\_Location\_Req message is sent by an external system to request the details registered in the CLD for a specific location or a list of locations.

##### 3.1.3.1 Message description

MS2SSN_Location_Req Elements	Attributes	Occ
<b>Header</b> ( <i>location:HeaderType</i> )		<b>1</b>
	Version (xs:string)	1
	TestId (xs:string)	0-1
	SentAt (xs:dateTime)	1
	From (xs:string)	1
	To (xs:string)	1
<b>Body</b> ( <i>location:MS2SSN_LocationDetails_RequestBodyType</i> )		<b>1</b>
<b>LocationRequestCriteria</b> ( <i>location:LocationRequestCriteriaType</i> )		<b>0-1</b>
	<b>Searchby5digitLoCode</b> ( <i>location:ExactLoCodeType</i> )	<b>1</b>
	<b>GISIScode</b> ( <i>location:GisisType</i> )	<b>0-1</b>
<b>LocationListRequestCriteria</b> ( <i>location:LocationListRequestCriteriaType</i> )		<b>0-1</b>

MS2SSN_Location_Req Elements	Attributes	Occ
	<b>EncodeListYesOrNo</b> (epc:YesNoEnumType)	<b>1</b>
	<b>SearchByApplicationCode</b> (location:ApplicationCodeType)	<b>0-1</b>
	<b>SearchbyListOfCountryCode</b> (location:SearchbyListOfCountryCodeType)	<b>0-1</b>
	<b>CountryCode</b> (epc:CountryCodeContentType)	<b>0-99</b>
	<b>SearchForUpdates</b> (location:SearchForUpdatesType)	<b>0-1</b>
	StartDateTime (xs:dateTime)	1
	EndDateTime (xs:dateTime)	1
	<b>SearchByBip</b> (epc:YesNoEnumType)	<b>0-1</b>
	<b>SearchByTransshipmentPort</b> (epc:YesNoEnumType)	<b>0-1</b>
	<b>SearchByName</b> (location:NameType)	<b>0-1</b>
	<b>SearchByLocode</b> (location:LoCodeType)	<b>0-1</b>

### 3.1.3.2 Business rules

The following table describes the applicable business rules. The detailed definition of the attributes is included in Annex B.

No	MS2SSN_Location_Req Element or Attribute	Action
1	From	Standard practice for the field is to include the reference identification of the originator of the data included in the message as defined in the IdM V2.
2	Body	A valid Body element shall include either the <b>LocationRequestCriteria</b> element or the <b>LocationListRequestCriteria</b> , not both.
3	Searchby5digitLoCode	Unique identifier of the location (concatenation of the 2-character ISO code of a country and a 3-character unique location identifier as defined by UNECE and/ or in SSN).
4	GISIScode	If GISIScode is included in the LocationRequestCriteria, the Searchby5digitLoCode should be included too
5	EncodeListYesOrNo	If the value of the attribute is set to Yes , the response will be provided in Base64
6	SearchByApplicationCode	Search criterion for the locations currently active in the maritime application specified by the application code/acronym.
7	SearchbyListOfCountryCode	Search criterion for the locations belonging to the list of countries.
8	SearchForUpdates	The search period.
9	SearchByBip	Search criterion for the locations approved as EU Border Inspection Posts.
10	SearchByTransshipmentPort	Search criterion for the locations where transshipment or landing operations of fishery products are authorized.
11	SearchByName	Search criterion for the locations for which the name with diacritics, or the name without diacritics, or any of the other location names, contains a pattern match of the input string.

No	MS2SSN_Location_Req Element or Attribute	Action
12	<i>SearchByLocode</i>	Search criterion for the locations for which the LoCode contains a pattern match of the input string.

### 3.1.3.3 Example

Example of a request message:

```
<soapenv:Envelope xmlns:soapenv="http://www.w3.org/2003/05/soap-envelope"
xmlns:urn="urn:eu.emsa.ssn.location">
  <soapenv:Header />
  <soapenv:Body>
    <urn:MS2SSN_Location_Req>
      <urn:Header Version="1.0" SentAt="2016-04-22T09:40:29Z" From="THETIS" To="SSN"/>
      <urn:Body><!--Optional:-->
        <urn:LocationRequestCriteria>
          <!--Optional:-->
          <urn:Searchby5digitLoCode>GRPIR</urn:Searchby5digitLoCode>
          <!--Optional:-->
          <urn:GISISCode>0027</urn:GISISCode>
        </urn:LocationRequestCriteria>
      </urn:Body>
    </urn:MS2SSN_Location_Req>
  </soapenv:Body>
</soapenv:Envelope>
```

### 3.1.4 SSN2MS\_Location\_Res message

The **SSN2MS\_Location\_Res** message is the response sent by CLD system to an external system which has requested location details from CLD using a **MS2SSN\_Location\_Req** message.

#### 3.1.4.1 Message description Message description

SSN2MS_Location_Res Elements	Attributes	Occ
<b>Header</b> ( <i>location:Header1Type</i> )		<b>1</b>
	Version (xs:string)	1
	TestId (xs:string)	0-1
	SentAt (xs:dateTime)	1
	From (xs:string)	1
	To (xs:string)	1
	StatusCode ( <i>location:StatusCodeEnumType</i> )	1
	StatusMessage (xs:string)	0-1
<b>Body</b> ( <i>location:SSN2MS_LocationDetails_ResponseBodyType</i> )		<b>0-1</b>
<b>LocationsListEncoded</b> ( <i>location:LocationsListEncodedType</i> )		<b>0-1</b>
	ZippedLocationListInBase64 (xs:base64Binary)	0-1
<b>LocationsListInXML</b> ( <i>location:LocationsListInXMLType</i> )		<b>0-1</b>
<b>LocationDetails</b> ( <i>location:LocationResponseDetailsType</i> )		<b>0-∞</b>
	<b>CreatedOn</b> ( <i>complex</i> )	<b>1</b>
	CreatedOn (xsd:dateTime)	1

SSN2MS_Location_Res Elements	Attributes	Occ
	CreatedBy (location:CreatedByType)	1
<b>LastUpdatedOn</b> (complex)		<b>0-1</b>
	LastUpdatedOn (xsd:dateTime)	1
	LastUpdatedBy (location:CreatedByType)	1
<b>IsActive</b> (epc:YesNoEnumType)		<b>1</b>
<b>Digit5LoCode</b> (location:Digit5LoCodeType)		<b>1</b>
	<b>LoCode</b> (location:ExactLoCodeType)	<b>1</b>
<b>LocationNameWithDiacritics</b> (location:NameType)		<b>0-1</b>
<b>LocationNameWithoutDiacritics</b> (location:NameType)		<b>1</b>
<b>Comments</b> (epc:string)		<b>0-1</b>
<b>CountryCode</b> (epc:CountryCodeContentType)		<b>1</b>
<b>Type</b> (location:LocationTypeEnumType)		<b>1</b>
<b>FunctionsUNECE</b> (location:FunctionsUNECEType)		<b>0-8</b>
	Function (location:Length1Type)	1
<b>LocationPosition</b> (epc: PositionType)		<b>0-1</b>
	<b>Latitude</b> (epc:LatitudeType)	<b>1</b>
	<b>Longitude</b> (epc:LongitudeType)	<b>1</b>
<b>LocationAreas</b> (location:CGDAreaType)		<b>0-10</b>
	<b>Name</b> (epc:string)	<b>0-1</b>
	<b>Category</b> (epc:string)	<b>0-1</b>
	<b>ReferenceKey</b> (epc:token)	<b>1</b>
	<b>Description</b> (epc:string)	<b>0-1</b>
<b>AlternativeLocationNames</b> (location:AlternativeLocationNamesType)		<b>0-1</b>
<b>LocName1</b> (location:LocationNamesType)		<b>0-1</b>
	<b>LocName</b> (location:NameType)	<b>1</b>
	<b>LastUpdateDetails</b> (location>LastUpdateDetailsType)	<b>1</b>
	<b>LastUpdatedOn</b> (xsd:dateTime)	<b>1</b>
	<b>LastUpdatedBy</b> (location:CreatedByType)	<b>1</b>
<b>LocName2</b> (location:LocationNamesType)		<b>0-1</b>
	<b>LocName</b> (location:NameType)	<b>1</b>
	<b>LastUpdateDetails</b> (location>LastUpdateDetailsType)	<b>1</b>
	<b>LastUpdatedOn</b> (xsd:dateTime)	<b>1</b>
	<b>LastUpdatedBy</b> (location:CreatedByType)	<b>1</b>
<b>LocName3</b> (location:LocationNamesType)		<b>0-1</b>
	<b>LocName</b> (location:NameType)	<b>1</b>
	<b>LastUpdateDetails</b> (location>LastUpdateDetailsType)	<b>1</b>
	<b>LastUpdatedOn</b> (xsd:dateTime)	<b>1</b>
	<b>LastUpdatedBy</b> (location:CreatedByType)	<b>1</b>
<b>LocName4</b> (location:LocationNamesType)		<b>0-1</b>
	<b>LocName</b> (location:NameType)	<b>1</b>
	<b>LastUpdateDetails</b> (location>LastUpdateDetailsType)	<b>1</b>

SSN2MS_Location_Res Elements	Attributes	Occ
	<b>LastUpdatedOn</b> (xsd:dateTime)	<b>1</b>
	<b>LastUpdatedBy</b> (location:CreatedByType)	<b>1</b>
<b>PortFacility</b> (location:PortFacilityType)		<b>0-500</b>
	<b>LastUpdateDetails</b> (location:LastUpdateDetailsType)	<b>1</b>
	<b>LastUpdatedOn</b> (xsd:dateTime)	<b>1</b>
	<b>LastUpdatedBy</b> (location:CreatedByType)	<b>1</b>
<b>UNECESubsiaryLocation</b> (epc:UNLoCodeContentType)		<b>0-1</b>
<b>PortFacilityDetails</b> (location:PortFacilityDetailsType)		<b>0-1</b>
	<b>Name</b> (epc:string)	<b>1</b>
	<b>Description</b> (epc:string)	<b>1</b>
	<b>LoCode</b> (location:LoCodeType)	<b>1</b>
	<b>GISIScode</b> (location:GisisType)	<b>1</b>
	<b>Position</b> (epc:PositionType)	<b>0-1</b>
	<b>Latitude</b> (epc:LatitudeType)	<b>1</b>
	<b>Longitude</b> (epc:LongitudeType)	<b>1</b>
<b>SSNSubsiaryLocations</b> (location:SSNSubsiaryLocationsType)		<b>0-99</b>
	<b>LoCode</b> (epc:UNLoCodeContentType)	<b>1</b>
	<b>LastUpdateDetails</b> (location:LastUpdateDetailsType)	<b>1</b>
	<b>LastUpdatedOn</b> (xsd:dateTime)	<b>1</b>
	<b>LastUpdatedBy</b> (location:CreatedByType)	<b>1</b>
<b>InSeca</b> (epc:YesNoEnumType)		<b>0-1</b>
<b>LocationAttributes</b> (location:LocationAttributesType)		<b>0-1</b>
	Bip (epc:YesNoEnumType)	1
	TransshipmentPort(epc:YesNoEnumType)	1
<b>InEU</b> (epc:YesNoEnumType)		<b>0-1</b>
<b>ActiveInlist</b> (location:ActiveInlistType)		<b>0-1</b>
	<b>ApplicationUsingLocation</b> (CompexType)	<b>1-99</b>
	Name (location:ApplicationCodeType)	1
	IsActive (epc:YesNoEnumType)	1
	LastUpdatedOn (xs:dateTime)	0-1

### 3.1.4.2 Business rules

The following table describes the XML message used for the transaction and the applicable business rules. The detailed definition of the attributes is included in Annex B.



No	SSN2MS_Location_Res Element or Attribute	Action
1	<i>Header</i>	<ol style="list-style-type: none"> <li>Standard practice for the To field is to include the reference identification of the requestor of the data defined in the corresponding request message.</li> <li>Standard practice for the FROM field is to identify "SSN" as the provider of the response message.</li> </ol>
2	<i>Body</i>	<ol style="list-style-type: none"> <li>A valid body, if included in the response, will include the data concerning a single location or a list of locations conforming with the criteria of the request.</li> <li>No quotation of the <i>Body</i> in the response signifies that the search query in the CLD database returned no results.</li> <li>The response shall retrieve and provide all the data registered in the CLD at the timestamp of the SentAt for the location (s) listed in the response message</li> <li>The results limit will be removed for the CLD responses provided as zipped base 64 file.</li> </ol>

### 3.1.4.3 Example

Example of a response message

```
<S:Envelope xmlns:env="http://www.w3.org/2003/05/soap-envelope" xmlns:S="http://www.w3.org/2003/05/soap-envelope">
  <env:Header/>
  <S:Body>
    <ns0:SSN2MS_Location_Res xmlns="http://www.iso.org/28005-2" xmlns:ns0="urn:eu.emsa.ssn.location">
      <ns0:Header Version="1.0" SentAt="2019-01-21T08:53:07.030Z" From="SSN" To="THETIS" StatusCode="OK"/>
      <ns0:Body>
        <ns0:LocationsListInXML>
          <ns0:LocationDetails>
            <ns0:LocationNameWithDiacritics>Piraeus</ns0:LocationNameWithDiacritics>
            <ns0:LocationNameWithoutDiacritics>Piraeus</ns0:LocationNameWithoutDiacritics>
            <ns0:CountryCode>GR</ns0:CountryCode>
            <ns0:Type>1</ns0:Type>
            <ns0:FunctionsUNECE Function="1"/>
            <ns0:LocationPosition>
              <Latitude>37.933334</Latitude>
              <Longitude>23.616667</Longitude>
            </ns0:LocationPosition>
            <ns0:PortFacility>
              <ns0:PortFacilityDetails>
                <ns0:Name>PUBLIC POWER CORPORATION DOCK</ns0:Name>
                <ns0:Description>PUBLIC POWER ORPORATION</ns0:Description>
                <ns0:LoCode>GRPIR</ns0:LoCode>
                <ns0:GISISCode>0027</ns0:GISISCode>
                <ns0:Position>
                  <Latitude>37.956667</Latitude>
```

```
<Longitude>23.605000</Longitude>
</ns0:Position>
</ns0:PortFacilityDetails>
<ns0:LastUpdateDetails>
  <ns0:LastUpdatedOn>2017-07-06T15:13:36.234Z</ns0:LastUpdatedOn>
  <ns0:LastUpdatedBy>SSN</ns0:LastUpdatedBy>
</ns0:LastUpdateDetails>
</ns0:PortFacility>
<ns0:SSNSubsidiaryLocations>
  <ns0:LoCode>TIN</ns0:LoCode>
  <ns0:LastUpdateDetails>
    <ns0:LastUpdatedOn>2017-07-06T15:13:36.234Z</ns0:LastUpdatedOn>
    <ns0:LastUpdatedBy>SSN</ns0:LastUpdatedBy>
  </ns0:LastUpdateDetails>
</ns0:SSNSubsidiaryLocations>
<ns0:LocationAttributes Bip="N" TranshipmentPort="N"/>
<ns0:LocationAreas ReferenceKey="KEY-1" Name="Traffic" Category="TSS" Description="Traffic
separation scheme"/>
<ns0:LocationAreas ReferenceKey="KEY-2" Name="Economic" Category="EEZ"
Description="Exclusive Economic Zone"/>
<ns0:ActiveInlist>
  <ns0:ApplicationUsingLocation Name="THETIS" IsActive="N" LastUpdatedOn="2017-01-
10T13:02:46.061Z"/>
  <ns0:ApplicationUsingLocation Name="SSN" IsActive="Y" LastUpdatedOn="2017-07-
06T15:13:36.234Z"/>
</ns0:ActiveInlist>
<ns0:DatabaseRecordInfo>
  <ns0:CreatedOn CreatedOn="2007-06-21T18:46:09Z" CreatedBy="SSN"/>
  <ns0:LastUpdatedOn LastUpdatedOn="2018-10-30T10:59:40.297413Z"
LastUpdatedBy="SSNADMIN"/>
  <ns0:IsActive>Y</ns0:IsActive>
</ns0:DatabaseRecordInfo>
<ns0:Digit5LoCode>
  <ns0:LoCode>GRPIR</ns0:LoCode>
</ns0:Digit5LoCode>
</ns0:LocationDetails>
</ns0:LocationsListInXML>
</ns0:Body>
</ns0:SSN2MS_Location_Res>
</S:Body>
</S:Envelope>
```

## 3.2 Get Location logs from CLD

### 3.2.1 Introduction

An external system can request a journal of changes (the "logs") of the details of an individual Location during a time period.

This section describes the different XML messages provided for this transaction.

### 3.2.2 Message flow

The following figure outlines the expected synchronous flow of XML messages related to this transaction.

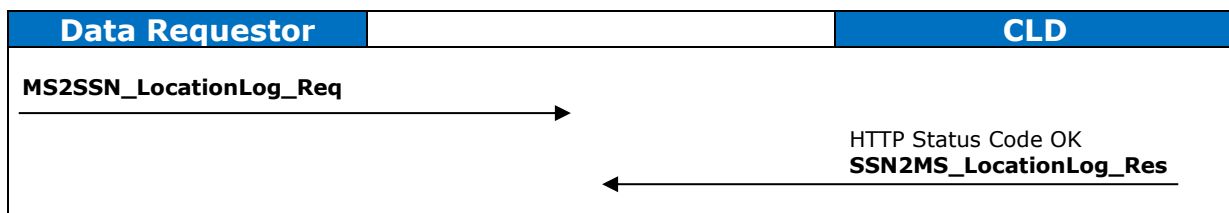

In accordance with the applicable wsdl (refer to Annex A), the request (QueryOperation) operation is provided by the CLD. It receives **MS2SSN\_LocationLog\_Req** requests from external systems and replies with **SSN2MS\_LocationLog\_Res** responses.

### 3.2.3 MS2SSN\_LocationLog\_Req message

The **MS2SSN\_LocationLog\_Req** message is sent by an external system to request the logs of changes of a specific Location record registered in the CLD.

#### 3.2.3.1 Message description

MS2SSN_LocationLog_Req Elements	Attributes	Occ
<b>Header</b> ( <i>location:HeaderType</i> )		<b>1</b>
	Version (xs:string)	1
	TestId (xs:string)	0-1
	SentAt (xs:dateTime)	1
	From (xs:string)	1
	To (xs:string)	1
<b>Body</b> ( <i>location:MS2SSN_SingleLocationLogs_RequestBodyType</i> )		<b>0-1</b>
	<b>SingleLocationLogsRequest</b> ( <i>location:SingleLocationLogsRequestType</i> )	<b>1</b>
	<b>Searchby5digitLoCode</b> ( <i>location:ExactLoCodeType</i> )	<b>1</b>
	<b>GISIScode</b> ( <i>location:GisisType</i> )	<b>0-1</b>
	<b>SearchLogsPeriod</b> ( <i>location:SearchLogsPeriodType</i> )	<b>0-1</b>
	StartDateTime (xs:dateTime)	1
	EndDateTime (xs:dateTime)	0-1

### 3.2.3.2 Business rules

The following table describes the XML message used for the transaction and the applicable business rules. The detailed definition of the attributes is included in Annex B.

No	MS2SSN_LocationLog_Req Element or Attribute	Action
1	From	Standard practice for the field is to include the reference identification of the originator of the data included in the message as defined in the IdM V2.
2	Body	<p>A valid Body element shall include the SingleLocationLogsRequest with at least the Searchby5digitLoCode defined or the Searchby5digitLoCode and GISIScode defined (messages quoting only the GISIScode are invalid)</p> <p>The request will always return the logs concerning a single location or (in the case that both Searchby5digitLoCode and GISIScode defined are defined in the request, a single port facility within a port.</p>
3	SearchLogsPeriod element	<ol style="list-style-type: none"> <li>1. StartDateTime will be a time within maximum 60 calendar days in the past with respect to SentAt timestamp of the request message.</li> <li>2. EndDateTime will be a timestamp:                             <ul style="list-style-type: none"> <li>• Within maximum 60 calendar days in the past with respect to SentAt timestamp of the request message. It may be equal to the SentAt timestamp, or</li> <li>• Equal to SentAt timestamp</li> </ul> </li> <li>3. EndDateTime &gt; StartDateTime (</li> <li>4. If EndDateTime is not provided, the value of EndDateTime to be considered for the search will be the SentAt timestamp</li> </ol>

### 3.2.3.3 Example

Example of a SOAP message:

```
<soapenv:Envelope xmlns:soapenv="http://www.w3.org/2003/05/soap-envelope"
xmlns:urn="urn:eu.emsa.ssn.location">
  <soapenv:Header/>
  <soapenv:Body>
    <urn:MS2SSN_LocationLog_Req>
      <urn:Header Version="1.0" SentAt="2019-01-21T09:41:20Z" From="nswitrom1" To="SSN"/>
      <urn:Body>
        <urn:SingleLocationLogsRequest>
          <urn:Searchby5digitLoCode>GRPIR</urn:Searchby5digitLoCode>
          <urn:GISISCode>0027</urn:GISISCode>
          <urn:SearchLogsPeriod StartDateTime="2018-12-11T00:00:01" EndDateTime="2019-01-21T09:41:20"/>
        </urn:SingleLocationLogsRequest>
      </urn:Body>
    </urn:MS2SSN_LocationLog_Req>
  </soapenv:Body>
</soapenv:Envelope>
```

</soapenv:Envelope>

### 3.2.4 SSN2MS\_LocationLog\_Res message

The **SSN2MS\_LocationLog\_Res** message is sent by CLD to an external system which has requested the logs of changes to a particular Location record in the CLD using a **MS2SSN\_LocationLog\_Req** message.

#### 3.2.4.1 Message description

SSN2MS_LocationLog_Res Elements	Attributes	Occ
<b>Header</b> ( <i>location:Header1Type</i> )		<b>1</b>
	Version (xs:string)	1
	TestId (xs:string)	0-1
	SentAt (xs:dateTime)	1
	From (xs:string)	1
	To (xs:string)	1
	StatusCode (location:StatusCodeEnumType)	1
	StatusMessage (xs:string)	0-1
<b>Body</b> ( <i>location:SSN2MS_LocationLogs_ResponseBodyType</i> )		<b>0-1</b>
<b>LocationLogsListInXML</b> ( <i>location:LocationsListInXMLType</i> )		<b>0-1</b>
<b>LocationLogsDetails</b> ( <i>location:LocationResponseDetailsType</i> )		<b>0-∞</b>
<b>DatabaseRecordInfo</b> ( <i>location:DatabaseRecordInfoType</i> )		<b>1</b>
<b>CreatedOn</b> ( <i>complex</i> )		<b>1</b>
	CreatedOn (xsd:dateTime)	1
	CreatedBy (location:CreatedByType)	1
<b>LastUpdateOn</b> ( <i>complex</i> )		<b>0-1</b>
	LastUpdatedOn (xsd:dateTime)	1
	LastUpdatedBy (location:CreatedByType)	1
<b>IsActive</b> ( <i>epc:YesNoEnumType</i> )		<b>1</b>
<b>Digit5LoCode</b> ( <i>location:Digit5LoCodeType</i> )		<b>1</b>
	<b>LoCode</b> ( <i>location:ExactLoCodeType</i> )	<b>1</b>
<b>LocationNameWithDiacritics</b> ( <i>location:NameType</i> )		<b>0-1</b>
<b>LocationNameWithoutDiacritics</b> ( <i>location:NameType</i> )		<b>1</b>
<b>Comments</b> ( <i>epc:string</i> )		<b>0-1</b>
<b>CountryCode</b> ( <i>epc:CountryCodeContentType</i> )		<b>1</b>
<b>Type</b> ( <i>location:LocationTypeEnumType</i> )		<b>1</b>
<b>FunctionsUNECE</b> ( <i>location:FunctionsUNECEType</i> )		<b>0-8</b>
	Function (location:Length1Type)	1
<b>LocationPosition</b> ( <i>epc: PositionType</i> )		<b>0-1</b>
	<b>Latitude</b> ( <i>epc:LatitudeType</i> )	<b>1</b>

SSN2MS_LocationLog_Res Elements	Attributes	Occ
	<b>Longitude</b> (epc:LongitudeType)	<b>1</b>
<b>LocationAreas</b> (location:CGDAreaType)		<b>0-10</b>
	<b>Name</b> (epc:string)	<b>0-1</b>
	<b>Category</b> (epc:string)	<b>0-1</b>
	<b>ReferenceKey</b> (epc:token)	<b>1</b>
	<b>Description</b> (epc:string)	<b>0-1</b>
<b>AlternativeLocationNames</b> (location:AlternativeLocationNamesType)		<b>0-1</b>
<b>LocName1</b> (location:LocationNamesType)		<b>0-1</b>
	<b>LocName</b> (location:NameType)	<b>1</b>
	<b>LastUpdateDetails</b> (location>LastUpdateDetailsType)	<b>1</b>
	<b>LastUpdatedOn</b> (xsd:dateTime)	<b>1</b>
	<b>LastUpdatedBy</b> (location:CreatedByType)	<b>1</b>
<b>LocName2</b> (location:LocationNamesType)		<b>0-1</b>
	<b>LocName</b> (location:NameType)	<b>1</b>
	<b>LastUpdateDetails</b> (location>LastUpdateDetailsType)	<b>1</b>
	<b>LastUpdatedOn</b> (xsd:dateTime)	<b>1</b>
	<b>LastUpdatedBy</b> (location:CreatedByType)	<b>1</b>
<b>LocName3</b> (location:LocationNamesType)		<b>0-1</b>
	<b>LocName</b> (location:NameType)	<b>1</b>
	<b>LastUpdateDetails</b> (location>LastUpdateDetailsType)	<b>1</b>
	<b>LastUpdatedOn</b> (xsd:dateTime)	<b>1</b>
	<b>LastUpdatedBy</b> (location:CreatedByType)	<b>1</b>
<b>LocName4</b> (location:LocationNamesType)		<b>0-1</b>
	<b>LocName</b> (location:NameType)	<b>1</b>
	<b>LastUpdateDetails</b> (location>LastUpdateDetailsType)	<b>1</b>
	<b>LastUpdatedOn</b> (xsd:dateTime)	<b>1</b>
	<b>LastUpdatedBy</b> (location:CreatedByType)	<b>1</b>
<b>PortFacility</b> (location:PortFacilityType)		<b>0-500</b>
	<b>LastUpdateDetails</b> (location>LastUpdateDetailsType)	<b>1</b>
	<b>LastUpdatedOn</b> (xsd:dateTime)	<b>1</b>
	<b>LastUpdatedBy</b> (location:CreatedByType)	<b>1</b>
<b>UNECESubsiaryLocation</b> (epc:UNLoCodeContentType)		<b>0-1</b>
<b>PortFacilityDetails</b> (location:PortFacilityDetailsType)		<b>0-1</b>
	<b>Name</b> (epc:string)	<b>1</b>
	<b>Description</b> (epc:string)	<b>1</b>
	<b>LoCode</b> (location:LoCodeType)	<b>1</b>
	<b>GISIScode</b> (location:GisisType)	<b>1</b>
	<b>Position</b> (epc:PositionType)	<b>0-1</b>
	<b>Latitude</b> (epc:LatitudeType)	<b>1</b>
	<b>Longitude</b> (epc:LongitudeType)	<b>1</b>
<b>SSNSubsiaryLocations</b> (location:SSNSubsiaryLocationsType)		<b>0-99</b>

SSN2MS_LocationLog_Res Elements	Attributes	Occ
	<b>LoCode</b> (epc:UNLoCodeContentType)	<b>1</b>
	<b>LastUpdateDetails</b> (location>LastUpdateDetailsType)	<b>1</b>
	<b>LastUpdatedOn</b> (xsd:dateTime)	<b>1</b>
	<b>LastUpdatedBy</b> (location:CreatedByType)	<b>1</b>
	<b>InSeca</b> (epc:YesNoEnumType)	<b>0-1</b>
	<b>LocationAttributes</b> (location:LocationAttributesType)	<b>0-1</b>
	Bip (epc:YesNoEnumType)	1
	TransshipmentPort (epc:YesNoEnumType)	1
	<b>InEU</b> (epc:YesNoEnumType)	<b>0-1</b>
	<b>ActiveInlist</b> (location:ActiveInlistType)	<b>0-1</b>
	<b>ApplicationUsingLocation</b> (CompexType)	<b>1-99</b>
	Name (location:ApplicationCodeType)	1
	IsActive (epc:YesNoEnumType)	1
	LastUpdatedOn (xs:dateTime)	0-1

### 3.2.4.2 Business rules

The following table describes the XML message used for the transaction and the applicable business rules. The detailed definition of the attributes is included in Annex B.

No	SSN2MS_LocationLog_Res Element or Attribute	Action
1	Header	<ol style="list-style-type: none"> <li>Standard practice for the To field is to include the reference identification of the resuestor of the data defined in the corresponding request message.</li> <li>Standard practice for the FROM field is to identify "SSN" as the provider of the response message.</li> </ol>
2	Body	A valid body, if included in the response, will include the data concerning a list reporting the changes made to a single location or a single port facility . Each repetition of the <i>LocationLogsDetails</i> element in the list return reports the data registered in CLD at the date identified by the LastUpdatedOn date time within the LocationLofDetails element

### 3.2.4.3 Example

Example of an SSN2MS\_LocationLog\_Res message:

```
<S:Envelope xmlns:env="http://www.w3.org/2003/05/soap-envelope" xmlns:S="http://www.w3.org/2003/05/soap-envelope">
  <env:Header/>
  <S:Body>
    <ns0:SSN2MS_LocationLog_Res xmlns="http://www.iso.org/28005-2" xmlns:ns0="urn:eu.emsa.ssn.location">
      <ns0:Header Version="1.0" SentAt="2019-01-21T09:03:29.727Z" From="SSN" To="nswitrom1"
      StatusCode="OK"/>
      <ns0:Body>
        <ns0:LocationLogsListInXML>
          <ns0:LocationLogsDetails>
            <ns0:LocationNameWithDiacritics>test_loc_2</ns0:LocationNameWithDiacritics>
```

```
<ns0:LocationNameWithoutDiacritics>test loc 2</ns0:LocationNameWithoutDiacritics>
<ns0:CountryCode>GR</ns0:CountryCode>
<ns0:Type>0</ns0:Type>
<ns0:AlternativeLocationNames>
  <ns0:LocName1>
    <ns0:LocName>test location 2</ns0:LocName>
    <ns0:LastUpdateDetails>
      <ns0:LastUpdatedOn>2017-02-14T10:00:00Z</ns0:LastUpdatedOn>
      <ns0:LastUpdatedBy>GRYYY</ns0:LastUpdatedBy>
    </ns0:LastUpdateDetails>
  </ns0:LocName1>
</ns0:AlternativeLocationNames>
<ns0:InSeca>Y</ns0:InSeca>
<ns0:LocationAttributes Bip="N" TranshipmentPort="N"/>
<ns0:LocationAreas ReferenceKey="KEY-1" Name="Traffic" Category="TSS"
Description="Traffic separation scheme"/>
<ns0:LocationAreas ReferenceKey="KEY-2" Name="Economic" Category="EEZ"
Description="Exclusive Economic Zone"/>
<ns0:DatabaseRecordInfo>
  <ns0:CreatedOn CreatedOn="2018-09-12T12:54:21.391Z" CreatedBy="GRPIR01"/>
  <ns0:LastUpdatedOn LastUpdatedOn="2018-09-12T12:54:21.391Z" LastUpdatedBy="GRPIR01"/>
  <ns0:IsActive>N</ns0:IsActive>
</ns0:DatabaseRecordInfo>
<ns0:Digit5LoCode>
  <ns0:LoCode>GRXX7</ns0:LoCode>
</ns0:Digit5LoCode>
</ns0:LocationLogsDetails>
</ns0:LocationLogsListInXML>
</ns0:Body>
</ns0:SSN2MS_LocationLog_Res>
</S:Body>
</S:Envelope>
```

## **3.3 Announcement mechanism**

### **3.3.1 Introduction**

An external system can subscribe to CLD for receiving the latest details of locations at each modification or creation of a location.

This section describes the different XML messages provided for this transaction.

### **3.3.2 Message flow**

The following figure outlines the expected two synchronous flows of XML messages (announcement requests and the announcements responses) related to this transaction.



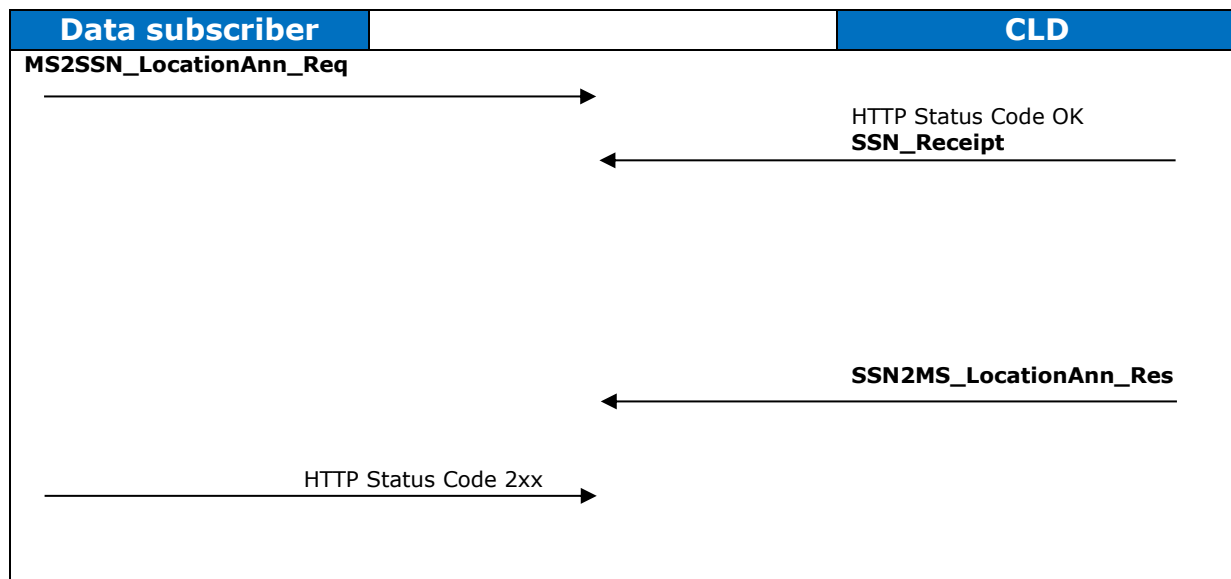

In accordance with the applicable wsdl (refer to Annex A):

- The subscription request (QueryOperation) operation is provided by the CLD. It receives **MS2SSN\_LocationAnn\_Req** requests from external systems and replies synchronously with an **SSN\_Receipt** message and HTTP Status 200 (OK) to the requestor.
- The request announcement Callback (QueryOperationCallback) operation is provided by the external system (DataSubscriberRole). It receives **SSN2MS\_LocationAnn\_Res** messages (one-way messages without a SOAP response) from CLD and replies to CLD an 2xx status code and an empty HTTP body, i.e. no SOAP envelope.

### 3.3.3 MS2SSN\_LocationAnn\_Req message

The **MS2SSN\_LocationAnn\_Req** message is sent by an MS to CLD for subscription to the Location data announcement (data “push”) service or cancelation of an existing subscription. The message contains information to enable the CLD system (CLD) to configure the service.

#### 3.3.3.1 Message description

MS2SSN_LocationAnn_Req Elements	Attributes	Occ
<b>Header</b> ( <i>location:HeaderType</i> )		<b>1</b>
	Version (xs:string)	1
	TestId (xs:string)	0-1
	SentAt (xs:dateTime)	1
	From (xs:string)	1
	To (xs:string)	1
<b>Body</b> ( <i>location:MS2SSN_LocationDetailsAnnouncement_RequestBodyType</i> )		<b>1</b>
	ESRefId ( <i>location:ESRefIdType</i> )	1
<b>Subscription</b>		<b>0-1</b>
	AnnouncementUrl ( <i>location:ESUrlType</i> )	1

MS2SSN_LocationAnn_Req Elements		Attributes	Occ
	<b>SearchCriteria</b> ( <i>location:AnnouncementSearchCriteriaType</i> )		<b>0-1</b>
	<b>Application</b> ( <i>location:ApplicationType</i> )		<b>0-1</b>
		ApplicationName( <i>location:ApplicationCodeType</i> )	1
	<b>SubscriptionPeriod</b> ( <i>location:SearchLogsPeriodType</i> )		<b>0-1</b>
		StartDateTime (xs:dateTime)	1
		EndDateTime (xs:dateTime)	0-1
	<b>SubscriptionLimitedtoCountries</b> ( <i>location:SubscriptionLimitedtoCountriesType</i> )		<b>0-1</b>
		<b>CountryCode</b> ( <i>epc:CountryCodeContentType</i> )	<b>1-99</b>
	<b>CancelSubscription</b> ( <i>location:CanceSubscriptionType</i> )		<b>0-1</b>
		ESRefIdofSubscriptionToCancel ( <i>location:ESRefIdType</i> )	1

### 3.3.3.2 Business rules

No	MS2SSN_LocationAnn_Req Element or Attribute	Action
1	From	Standard practice for the field is to include the reference identification of the originator of the data included in the message as defined in the IdM V2.
2	Body	A valid Body shall define <ul style="list-style-type: none"> <li>• The <i>ESRefId</i> attribute and</li> <li>• either the <i>Subscription</i> or the <i>CancelSubscription</i> element (choice).</li> </ul>
3	ESRefId	Must be unique for all the announcement requests provided by the external system
4	<i>Subscription</i>	A valid <i>Subscription</i> element defines the subscriber endpoint URL and the <i>SearchCriteria</i> .
5	<i>AnnouncementUrl</i>	The URL of the subscriber SOAP node receives the CLD announcements.
6	<i>SearchCriteria</i>	A valid <i>SearchCriteria</i> shall define at least one of the <i>Application</i> , <i>SubscriptionPeriod</i> , <i>SubscriptionLimitedtoCountries</i> elements
7	<i>Application</i>	Search criterion for the locations currently active in the maritime application specified by the application code/acronym.
8	<i>SubscriptionPeriod</i>	1. StartDateTime will be a timestamp: <ul style="list-style-type: none"> <li>• Within maximum 60 calendar days in the future with respect to SentAt timestamp of the Announcement request message, or</li> <li>• Equal to SentAt timestamp</li> </ul> 2. EndDateTime, if provided, will be any future timestamp with respect to SentAt where EndDateTime > StartDateTime 3. If EndDateTime is not provided, CLD will push all the records updates in the CLD starting from the StartDateTime. CLD will continue pushing announcements to the service subscriber
9	<i>SubscriptionLimitedtoCountries</i>	Search criterion for the locations belong the list of countries.
10	<i>CancelSubscription</i>	The <i>ESRefIdofSubscriptionToCancel</i> Should be always quoted in case of the cancellation of a previous subscription. The value of the

No	MS2SSN_LocationAnn_Req Element or Attribute	Action
		attribute points to the <i>ESRefId</i> of the announcement request that is to be cancelled.

### 3.3.3.3 Example

Example of a SOAP message for a valid subscription:

```
<soap:Envelope xmlns:soap="http://www.w3.org/2003/05/soap-envelope" xmlns:urn="urn:eu.emsa.ssn.location">
  <soap:Header/>
  <soap:Body>
    <urn:MS2SSN_LocationAnn_Req>
      <urn:Header Version="1.0" SentAt="2019-01-16T09:41:53Z" From="pt_nca_qa2" To="SSN"/>
      <urn:Body ESRefId="CLD_TEST_20190116094153">
        <urn:Subscription AnnouncementUrl="https://datasubscriber/CLDLocationService">
          <urn:SearchCriteria>
            <urn:Application ApplicationName="SSN"/>
            <urn:SubscriptionPeriod StartDateTime="2019-01-16T10:00:00Z"/>
            <urn:SubscriptionLimitedtoCountries>
              <urn:CountryCode>PT</urn:CountryCode>
            </urn:SubscriptionLimitedtoCountries>
          </urn:SearchCriteria>
        </urn:Subscription>
      </urn:Body>
    </urn:MS2SSN_LocationAnn_Req>
  </soap:Body>
</soap:Envelope>
```

Example of a SOAP message for a valid subscription cancelation:

```
<soap:Envelope xmlns:soap="http://www.w3.org/2003/05/soap-envelope" xmlns:urn="urn:eu.emsa.ssn.location">
  <soap:Header/>
  <soap:Body>
    <urn:MS2SSN_LocationAnn_Req>
      <urn:Header Version="1.0" SentAt="2019-01-16T09:41:53Z" From="pt_nca_qa2" To="SSN"/>
      <urn:Body ESRefId="CLD_TEST_20190116094154">
        <urn:CancelSubscription ESRefIdofSubscriptionToCancel="CLD_TEST_20190116094153"/>
      </urn:Body>
    </urn:MS2SSN_LocationAnn_Req>
  </soap:Body>
</soap:Envelope>
```

### 3.3.4 SSN2MS\_LocationAnn\_Res message

The **SSN2MS\_LocationAnn\_Res** message is sent by CLD to a subscriber to the Location announcement (data "push") service. The message contains all the information registered in the most recent version (the one created just before the dispatch of the announcement message) of the location records in the CLD.

### 3.3.4.1 Message description

SSN2MS_LocationAnn_Res Elements	Attributes	Occ
<b>Header</b> ( <i>location:Header1Type</i> )		<b>1</b>
	Version (xs:string)	1
	TestId (xs:string)	0-1
	SentAt (xs:dateTime)	1
	From (xs:string)	1
	To (xs:string)	1
	StatusCode ( <i>location:StatusCodeEnumType</i> )	1
	StatusMessage (xs:string)	0-1
<b>Body</b> ( <i>location:SSN2MS_LocationAnn_ResponseBodyType</i> )		<b>0-1</b>
ESRefId ( <i>location:ESRefIdType</i> )		1
SSNRefId ( <i>location:ESRefIdType</i> )		1
<b>LocationDetails</b> ( <i>location:LocationResponseDetailsType</i> )		<b>1-∞</b>
<b>DatabaseRecordInfo</b> ( <i>location:DatabaseRecordInfoType</i> )		<b>1</b>
<b>CreatedOn</b> ( <i>complex</i> )		<b>1</b>
	CreatedOn (xsd:dateTime)	1
	CreatedBy ( <i>location:CreatedByType</i> )	1
<b>LastUpdateOn</b> ( <i>complex</i> )		<b>0-1</b>
	LastUpdatedOn (xsd:dateTime)	1
	LastUpdatedBy ( <i>location:CreatedByType</i> )	1
<b>IsActive</b> ( <i>epc:YesNoEnumType</i> )		<b>1</b>
<b>Digit5LoCode</b> ( <i>location:Digit5LoCodeType</i> )		<b>1</b>
	<b>LoCode</b> ( <i>location:ExactLoCodeType</i> )	<b>1</b>
<b>LocationNameWithDiacritics</b> ( <i>location:NameType</i> )		<b>0-1</b>
<b>LocationNameWithoutDiacritics</b> ( <i>location:NameType</i> )		<b>1</b>
<b>Comments</b> ( <i>epc:string</i> )		<b>0-1</b>
<b>CountryCode</b> ( <i>epc:CountryCodeContentType</i> )		<b>1</b>
<b>Type</b> ( <i>location:LocationTypeEnumType</i> )		<b>1</b>
<b>FunctionsUNECE</b> ( <i>location:FunctionsUNECEType</i> )		<b>0-8</b>
	Function ( <i>location:Length1Type</i> )	1
<b>LocationPosition</b> ( <i>epc:PositionType</i> )		<b>0-1</b>
	<b>Latitude</b> ( <i>epc:LatitudeType</i> )	<b>1</b>
	<b>Longitude</b> ( <i>epc:LongitudeType</i> )	<b>1</b>
<b>LocationAreas</b> ( <i>location:CGDAreaType</i> )		<b>0-10</b>
	<b>Name</b> ( <i>epc:string</i> )	<b>0-1</b>
	<b>Category</b> ( <i>epc:string</i> )	<b>0-1</b>
	<b>ReferenceKey</b> ( <i>epc:token</i> )	<b>1</b>
	<b>Description</b> ( <i>epc:string</i> )	<b>0-1</b>
<b>AlternativeLocationNames</b> ( <i>location:AlternativeLocationNamesType</i> )		<b>0-1</b>

SSN2MS_LocationAnn_Res		Attributes	Occ
Elements			
	<b>LocName1</b> ( <i>location:LocationNamesType</i> )		<b>0-1</b>
	<b>LocName</b> ( <i>location:NameType</i> )		<b>1</b>
	<b>LastUpdateDetails</b> ( <i>location&gt;LastUpdateDetailsType</i> )		<b>1</b>
	<b>LastUpdatedOn</b> ( <i>xsd:dateTime</i> )		<b>1</b>
	<b>LastUpdatedBy</b> ( <i>location:CreatedByType</i> )		<b>1</b>
	<b>LocName2</b> ( <i>location:LocationNamesType</i> )		<b>0-1</b>
	<b>LocName</b> ( <i>location:NameType</i> )		<b>1</b>
	<b>LastUpdateDetails</b> ( <i>location&gt;LastUpdateDetailsType</i> )		<b>1</b>
	<b>LastUpdatedOn</b> ( <i>xsd:dateTime</i> )		<b>1</b>
	<b>LastUpdatedBy</b> ( <i>location:CreatedByType</i> )		<b>1</b>
	<b>LocName3</b> ( <i>location:LocationNamesType</i> )		<b>0-1</b>
	<b>LocName</b> ( <i>location:NameType</i> )		<b>1</b>
	<b>LastUpdateDetails</b> ( <i>location&gt;LastUpdateDetailsType</i> )		<b>1</b>
	<b>LastUpdatedOn</b> ( <i>xsd:dateTime</i> )		<b>1</b>
	<b>LastUpdatedBy</b> ( <i>location:CreatedByType</i> )		<b>1</b>
	<b>LocName4</b> ( <i>location:LocationNamesType</i> )		<b>0-1</b>
	<b>LocName</b> ( <i>location:NameType</i> )		<b>1</b>
	<b>LastUpdateDetails</b> ( <i>location&gt;LastUpdateDetailsType</i> )		<b>1</b>
	<b>LastUpdatedOn</b> ( <i>xsd:dateTime</i> )		<b>1</b>
	<b>LastUpdatedBy</b> ( <i>location:CreatedByType</i> )		<b>1</b>
	<b>PortFacility</b> ( <i>location:PortFacilityType</i> )		<b>0-500</b>
	<b>LastUpdateDetails</b> ( <i>location&gt;LastUpdateDetailsType</i> )		<b>1</b>
	<b>LastUpdatedOn</b> ( <i>xsd:dateTime</i> )		<b>1</b>
	<b>LastUpdatedBy</b> ( <i>location:CreatedByType</i> )		<b>1</b>
	<b>UNECESubsiaryLocation</b> ( <i>epc:UNLoCodeContentType</i> )		<b>0-1</b>
	<b>PortFacilityDetails</b> ( <i>location:PortFacilityDetailsType</i> )		<b>0-1</b>
	<b>Name</b> ( <i>epc:string</i> )		<b>1</b>
	<b>Description</b> ( <i>epc:string</i> )		<b>1</b>
	<b>LoCode</b> ( <i>location:LoCodeType</i> )		<b>1</b>
	<b>GISIScode</b> ( <i>location:GisisType</i> )		<b>1</b>
	<b>Position</b> ( <i>epc:PositionType</i> )		<b>0-1</b>
	<b>Latitude</b> ( <i>epc:LatitudeType</i> )		<b>1</b>
	<b>Longitude</b> ( <i>epc:LongitudeType</i> )		<b>1</b>
	<b>SSNSubsiaryLocations</b> ( <i>location:SSNSubsiaryLocationsType</i> )		<b>0-99</b>
	<b>LoCode</b> ( <i>epc:UNLoCodeContentType</i> )		<b>1</b>
	<b>LastUpdateDetails</b> ( <i>location&gt;LastUpdateDetailsType</i> )		<b>1</b>
	<b>LastUpdatedOn</b> ( <i>xsd:dateTime</i> )		<b>1</b>
	<b>LastUpdatedBy</b> ( <i>location:CreatedByType</i> )		<b>1</b>

SSN2MS_LocationAnn_Res Elements		Attributes	Occ
		<b>InSeca</b> (epc:YesNoEnumType)	<b>0-1</b>
		<b>LocationAttributes</b> (location:LocationAttributesType)	<b>0-1</b>
		Bip (epc:YesNoEnumType)	1
		TranshipmentPort (epc:YesNoEnumType)	1
		<b>InEU</b> (epc:YesNoEnumType)	<b>0-1</b>
		<b>ActiveInlist</b> (location:ActiveInlistType)	<b>0-1</b>
		<b>ApplicationUsingLocation</b> (ComplexType)	<b>1-99</b>
		Name (location:ApplicationCodeType)	1
		IsActive (epc:YesNoEnumType)	1
		LastUpdatedOn (xs:dateTime)	0-1

### 3.3.4.2 Business rules

The following table describes the applicable business rules. The detailed definition of the attributes is included in Annex B

No	SSN2MS_LocationAnn_Res Element/ Attribute	Action
1	Header	<ul style="list-style-type: none"> <li>Standard practice for the To field is to include the reference identification of the resuestor of the data defined in the corresponding request message.</li> <li>Standard practice for the FROM field is to identify "SSN" as the provider of the response message.</li> </ul>
2	Body	<p>A valid body will include</p> <ul style="list-style-type: none"> <li>The ESRefId is the ID defined in the corresponding</li> <li>The SSNRefId is the unique Reference id given by CLD in Announcement messages.</li> <li>the data concerning the updated locations.</li> </ul>

### 3.3.4.3 Example

Example of a SOAP message for Location data announcement:

```
<?xml version='1.0' encoding='UTF-8'?>
<S:Envelope xmlns:env="http://www.w3.org/2003/05/soap-envelope" xmlns:S="http://www.w3.org/2003/05/soap-envelope">
  <env:Header/>
  <S:Body>
    <ns0:SSN2MS_LocationAnn_Res xmlns="http://www.iso.org/28005-2" xmlns:ns0="urn:eu.emsa.ssn.location">
      <ns0:Header Version="1.0" SentAt="2019-01-21T08:14:06.187Z" From="SSN" To="GRPIR01" StatusCode="OK" />
      <ns0:Body ESRefId="LocationAnn_yt_20180618_1" SSNRefId="1548058446173">
        <ns0:LocationDetails>
          <ns0:LocationNameWithDiacritics>Achladi</ns0:LocationNameWithDiacritics>
          <ns0:LocationNameWithoutDiacritics>Achladi</ns0:LocationNameWithoutDiacritics>
          <ns0:CountryCode>GR</ns0:CountryCode>
          <ns0:Type>1</ns0:Type>
          <ns0:FunctionsUNECE Function="1" />
        </ns0:LocationDetails>
      </ns0:Body>
    </ns0:SSN2MS_LocationAnn_Res>
  </S:Body>
</S:Envelope>
```

```
<ns0:LocationPosition>
  <Latitude>-6.700000</Latitude>
  <Longitude>112.216667</Longitude>
</ns0:LocationPosition>
<ns0:PortFacility>
  <ns0:PortFacilityDetails>
    <ns0:Name>AGROINVEST S.A., ACHLADI-FTHIOTIS-GREECE</ns0:Name>
    <ns0:Description>UNLOADING/LOADING GRAINS,OIL SEED AND PRODUCT DERIVED OF</ns0:Description>
    <ns0:LoCode>GRACL</ns0:LoCode>
    <ns0:GISISCode>0001</ns0:GISISCode>
    <ns0:Position>
      <Latitude>38.884167</Latitude>
      <Longitude>22.818055</Longitude>
    </ns0:Position>
  </ns0:PortFacilityDetails>
  <ns0>LastUpdateDetails>
    <ns0>LastUpdatedOn>2017-05-11T12:20:54.812716Z</ns0>LastUpdatedOn>
    <ns0>LastUpdatedBy>SSN</ns0>LastUpdatedBy>
  </ns0>LastUpdateDetails>
</ns0:PortFacility>
<ns0:LocationAttributes Bip="N" TranshipmentPort="N" />
<ns0:ActiveInList>
  <ns0:ApplicationUsingLocation Name="THETIS" IsActive="Y" LastUpdatedOn="2017-02-20T14:55:03.244575Z" />
  <ns0:ApplicationUsingLocation Name="SSN" IsActive="Y" LastUpdatedOn="2018-10-30T11:00:46.365017Z" />
</ns0:ActiveInList>
<ns0:DatabaseRecordInfo>
  <ns0:CreatedOn CreatedOn="2007-06-21T18:46:09Z" CreatedBy="SSN" />
  <ns0:IsActive>Y</ns0:IsActive>
</ns0:DatabaseRecordInfo>
<ns0:Digit5LoCode>
  <ns0:LoCode>GRACL</ns0:LoCode>
</ns0:Digit5LoCode>
</ns0:LocationDetails>
<ns0:LocationDetails>
  <ns0:LocationNameWithDiacritics>test_loc_21 -2test</ns0:LocationNameWithDiacritics>
  <ns0:LocationNameWithoutDiacritics>test loc 21</ns0:LocationNameWithoutDiacritics>
  <ns0:CountryCode>GR</ns0:CountryCode>
  <ns0:Type>0</ns0:Type>
  <ns0:LocationPosition>
    <Latitude>55.000000</Latitude>
    <Longitude>66.000000</Longitude>
  </ns0:LocationPosition>
  <ns0:AlternativeLocationNames>
    <ns0:LocName1>
      <ns0:LocName>test location 2</ns0:LocName>
      <ns0>LastUpdateDetails>
        <ns0>LastUpdatedOn>2018-09-19T07:35:36.835Z</ns0>LastUpdatedOn>
        <ns0>LastUpdatedBy>GRYY3</ns0>LastUpdatedBy>
      </ns0>LastUpdateDetails>
    </ns0:LocName1>
    <ns0:LocName2>
      <ns0:LocName>test_loc_21 other</ns0:LocName>
      <ns0>LastUpdateDetails>
        <ns0>LastUpdatedOn>2018-09-19T07:35:36.835Z</ns0>LastUpdatedOn>
        <ns0>LastUpdatedBy>SSN</ns0>LastUpdatedBy>
      </ns0>LastUpdateDetails>
    </ns0:LocName2>
  </ns0:AlternativeLocationNames>
</ns0:PortFacility>
  <ns0:PortFacilityDetails>
    <ns0:Name>name</ns0:Name>
    <ns0:Description>desc</ns0:Description>
    <ns0:LoCode>PTLIS</ns0:LoCode>
    <ns0:GISISCode>0002</ns0:GISISCode>
    <ns0:Position>
      <Latitude>45.000000</Latitude>
      <Longitude>90.000000</Longitude>
    </ns0:Position>
```

```

</ns0:PortFacilityDetails>
<ns0:LastUpdateDetails>
  <ns0:LastUpdatedOn>2018-09-19T07:35:36.835Z</ns0:LastUpdatedOn>
  <ns0:LastUpdatedBy>GRPIR01</ns0:LastUpdatedBy>
</ns0:LastUpdateDetails>
</ns0:PortFacility>
<ns0:PortFacility>
  <ns0:PortFacilityDetails>
    <ns0:Name>name</ns0:Name>
    <ns0:Description>desc</ns0:Description>
    <ns0:LoCode>GRXX</ns0:LoCode>
    <ns0:GISISCode>0002</ns0:GISISCode>
    <ns0:Position>
      <Latitude>45.000000</Latitude>
      <Longitude>90.000000</Longitude>
    </ns0:Position>
  </ns0:PortFacilityDetails>
  <ns0:LastUpdateDetails>
    <ns0:LastUpdatedOn>2017-02-14T10:00:00Z</ns0:LastUpdatedOn>
    <ns0:LastUpdatedBy>GRPIR01</ns0:LastUpdatedBy>
  </ns0:LastUpdateDetails>
</ns0:PortFacility>
<ns0:SSNSubsiaryLocations>
  <ns0:LoCode>XXX</ns0:LoCode>
  <ns0:LastUpdateDetails>
    <ns0:LastUpdatedOn>2018-09-19T07:35:36.835Z</ns0:LastUpdatedOn>
    <ns0:LastUpdatedBy>GRPIR01</ns0:LastUpdatedBy>
  </ns0:LastUpdateDetails>
</ns0:SSNSubsiaryLocations>
<ns0:InSeca>Y</ns0:InSeca>
<ns0:LocationAttributes Bip="N" TranshipmentPort="N" />

  <urn:LocationAreas ReferenceKey="KEY-1" Name="Traffic" Category="TSS" Description="Traffic
separation scheme"/>
  <urn:LocationAreas ReferenceKey="KEY-2" Name="Economic" Category="EEZ" Description="Exclusive
Economic Zone"/>
  <ns0:DatabaseRecordInfo>
    <ns0:CreatedOn CreatedOn="2018-08-02T08:20:41.549Z" CreatedBy="GRPIR01" />
    <ns0:LastUpdatedOn LastUpdatedOn="2019-01-21T08:13:57.645Z" LastUpdatedBy="GRPIR01" />
    <ns0:IsActive>N</ns0:IsActive>
  </ns0:DatabaseRecordInfo>
  <ns0:Digit5LoCode>
    <ns0:LoCode>GRXX5</ns0:LoCode>
  </ns0:Digit5LoCode>
</ns0:LocationDetails>
<ns0:LocationDetails>
  <ns0:LocationNameWithDiacritics>Ejddqfyçãö</ns0:LocationNameWithDiacritics>
  <ns0:LocationNameWithoutDiacritics>Ejddqfyçao</ns0:LocationNameWithoutDiacritics>

<ns0:Comments>iAznX9TQ0k0rsz21HXnKym1h0CFHy8aaEBXyWQV5AxZqHV3xHGGkrj5Pk8zKXk00w3aTKzZVC7o4DD7IFEF89
SgpXiPILoexJNLbidVAKstpu1C2aH6Fqw2um6fPXwUnX09hd5VHEEJlvWdkdPbA1JzStzDKzWGRrE8e3XKCJdqzqytwnCpRISXPZ
G7F3d2eIE53TwYoIr9rt9MQgALUinauM33e1X6GhRF1Nu3sYy2nBvUIpiE0TsJNMOGs69</ns0:Comments>
  <ns0:CountryCode>PT</ns0:CountryCode>
  <ns0:Type>0</ns0:Type>
  <ns0:FunctionsUNECE Function="1" />
  <ns0:FunctionsUNECE Function="2" />
  <ns0:FunctionsUNECE Function="3" />
  <ns0:FunctionsUNECE Function="4" />
  <ns0:FunctionsUNECE Function="5" />
  <ns0:FunctionsUNECE Function="6" />
  <ns0:FunctionsUNECE Function="7" />
  <ns0:LocationPosition>
    <Latitude>-89.587341</Latitude>
    <Longitude>-94.026793</Longitude>
  </ns0:LocationPosition>
  <ns0:AlternativeLocationNames>
    <ns0:LocName1>
      <ns0:LocName>Yyisdnao 2</ns0:LocName>
      <ns0:LastUpdateDetails>
        <ns0:LastUpdatedOn>2018-08-29T11:22:41Z</ns0:LastUpdatedOn>

```



```
<ns0:LastUpdatedBy>pt_nca_qa2</ns0:LastUpdatedBy>
</ns0:LastUpdateDetails>
</ns0:LocName1>
<ns0:LocName2>
  <ns0:LocName>Ejdqfycao 2</ns0:LocName>
  <ns0:LastUpdateDetails>
    <ns0:LastUpdatedOn>2018-05-17T16:24:45Z</ns0:LastUpdatedOn>
    <ns0:LastUpdatedBy>pt_nca_qa2</ns0:LastUpdatedBy>
  </ns0:LastUpdateDetails>
</ns0:LocName2>
<ns0:LocName3>
  <ns0:LocName>Wzperyciao 2</ns0:LocName>
  <ns0:LastUpdateDetails>
    <ns0:LastUpdatedOn>2018-08-29T11:22:41Z</ns0:LastUpdatedOn>
    <ns0:LastUpdatedBy>pt_nca_qa2</ns0:LastUpdatedBy>
  </ns0:LastUpdateDetails>
</ns0:LocName3>
<ns0:LocName4>
  <ns0:LocName>Xzyitkcao 2</ns0:LocName>
  <ns0:LastUpdateDetails>
    <ns0:LastUpdatedOn>2018-08-29T11:22:40Z</ns0:LastUpdatedOn>
    <ns0:LastUpdatedBy>pt_nca_qa2</ns0:LastUpdatedBy>
  </ns0:LastUpdateDetails>
</ns0:LocName4>
</ns0:AlternativeLocationNames>
<ns0:PortFacility>
  <ns0:PortFacilityDetails>
    <ns0:Name>Esfeucku1</ns0:Name>
</ns0:PortFacilityDetails>
</ns0:PortFacility>
<ns0:Description>mYrmF07H9A3Tlm4Jrz9fvX1JUsVdmlBrqo0j0fACPjdbreb1UyIzXzgrs37mjnuz2xs64X8RLoxNJ9Hdw9Q
7rUsb85wFuQ94gLz22AaAYU7gngONYqCyqUuce3QFgFYli6FWFFkduP8B0sa8VhdP4XGpgLfxbQN53GfT1uPgHQLhXR3L9x4biE
rwJrEisDvh6CK9YABXT1QBSYOnH7bRkt3JT3ZePeTOH7z7INlmJZo48V9kzSx0WjBQdtYsMN</ns0:Description>
  <ns0:LoCode>PTMRY</ns0:LoCode>
  <ns0:GISISCode>4515</ns0:GISISCode>
  <ns0:Position>
    <Latitude>-89.587341</Latitude>
    <Longitude>-94.026793</Longitude>
  </ns0:Position>
</ns0:PortFacilityDetails>
<ns0:LastUpdateDetails>
  <ns0:LastUpdatedOn>2018-05-17T16:24:45Z</ns0:LastUpdatedOn>
  <ns0:LastUpdatedBy>pt_nca_qa2</ns0:LastUpdatedBy>
</ns0:LastUpdateDetails>
</ns0:PortFacility>
<ns0:PortFacility>
  <ns0:PortFacilityDetails>
    <ns0:Name>Esfeucku</ns0:Name>
    <ns0:Description>desc</ns0:Description>
    <ns0:LoCode>PTMRY</ns0:LoCode>
    <ns0:GISISCode>4514</ns0:GISISCode>
    <ns0:Position>
      <Latitude>-89.587341</Latitude>
      <Longitude>-94.026793</Longitude>
    </ns0:Position>
  </ns0:PortFacilityDetails>
<ns0:LastUpdateDetails>
  <ns0:LastUpdatedOn>2018-05-17T16:24:45Z</ns0:LastUpdatedOn>
  <ns0:LastUpdatedBy>pt_nca_qa3</ns0:LastUpdatedBy>
</ns0:LastUpdateDetails>
</ns0:PortFacility>
<ns0:SSNSubsiaryLocations>
  <ns0:LoCode>MRY</ns0:LoCode>
  <ns0:LastUpdateDetails>
    <ns0:LastUpdatedOn>2018-05-17T16:24:45Z</ns0:LastUpdatedOn>
    <ns0:LastUpdatedBy>pt_nca_qa2</ns0:LastUpdatedBy>
  </ns0:LastUpdateDetails>
</ns0:SSNSubsiaryLocations>
<ns0:InSeca>Y</ns0:InSeca>
<ns0:LocationAttributes Bip="Y" TranshipmentPort="N" />
<ns0:DatabaseRecordInfo>
```

```

        <ns0:CreatedOn CreatedOn="2018-08-29T14:31:56.674Z" CreatedBy="FERRETI" />
        <ns0:LastUpdatedOn LastUpdatedOn="2018-12-14T14:27:54.396Z" LastUpdatedBy="FERRETI" />
        <ns0:IsActive>N</ns0:IsActive>
    </ns0:DatabaseRecordInfo>
    <ns0:Digit5LoCode>
        <ns0:LoCode>PTMRY</ns0:LoCode>
    </ns0:Digit5LoCode>
</ns0:LocationDetails>
<ns0:LocationDetails>
    <ns0:LocationNameWithDiacritics>Moni Vatopediou</ns0:LocationNameWithDiacritics>
    <ns0:LocationNameWithoutDiacritics>Moni Vatopediou</ns0:LocationNameWithoutDiacritics>
    <ns0:CountryCode>GR</ns0:CountryCode>
    <ns0:Type>1</ns0:Type>
    <ns0:FunctionsUNECE Function="1" />
    <ns0:LocationPosition>
        <Latitude>40.300000</Latitude>
        <Longitude>24.200000</Longitude>
    </ns0:LocationPosition>
    <ns0:LocationAttributes Bip="N" TranshipmentPort="N" />
    <ns0:ActiveInlist>
        <ns0:ApplicationUsingLocation Name="SSN" IsActive="Y" LastUpdatedOn="2018-10-
30T11:06:13.583085Z" />
    </ns0:ActiveInlist>
    <ns0:DatabaseRecordInfo>
        <ns0:CreatedOn CreatedOn="2018-10-09T08:36:41.150049Z" CreatedBy="SSN" />
        <ns0:IsActive>Y</ns0:IsActive>
    </ns0:DatabaseRecordInfo>
    <ns0:Digit5LoCode>
        <ns0:LoCode>GRMVO</ns0:LoCode>
    </ns0:Digit5LoCode>
</ns0:LocationDetails>
</ns0:Body>
</ns0:SSN2MS_LocationAnn_Res>
</S:Body>
</S:Envelope>

```

## 3.4 Notification mechanism

### 3.4.1 Introduction

The **MS2SSN\_Location\_Not** message is sent by an external system to notify CLD of new insertions or updates of locations.

This notification contains all the detailed information regarding a location. CLD will store all the details and may provide the information to other external system when requested.

### 3.4.2 Message flow

The following figure outlines the expected synchronous flow of XML messages related to this transaction.

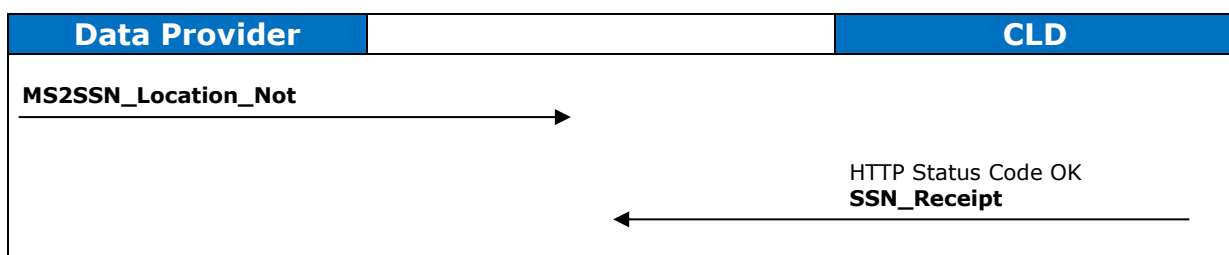

In accordance with the applicable wsdl (refer to Annex A), the request (notify operation) operation is provided by the CLD. It receives **MS2SSN\_Location\_Not** requests from external systems and replies with **SSN\_Receipt** messages.

### 3.4.3 MS2SSN\_Location\_Not message

#### 3.4.3.1 Message description

MS2SSN_Location_Not Elements	Attributes	Occ
<b>Header</b> ( <i>location:HeaderType</i> )		<b>1</b>
	Version (xs:string)	1
	TestId (xs:string)	0-1
	SentAt (xs:dateTime)	1
	From (xs:string)	1
	To (xs:string)	1
<b>Body</b> ( <i>location:MS2SSN_LocationNotification_BodyType</i> )		<b>1</b>
<b>LocationNotificationDetails</b> ( <i>location: LocationNotificationDetailsType</i> )		<b>1</b>
<b>LocationNameWithDiacritics</b> ( <i>location:NameType</i> )		<b>0-1</b>
<b>LocationNameWithoutDiacritics</b> ( <i>location:NameType</i> )		<b>1</b>
<b>Comments</b> ( <i>epc:string</i> )		<b>0-1</b>
<b>CountryCode</b> ( <i>epc:CountryCodeContentType</i> )		<b>1</b>
<b>Type</b> ( <i>location:LocationTypeEnumType</i> )		<b>1</b>
<b>FunctionsUNECE</b> ( <i>location:FunctionsUNECEType</i> )		<b>0-8</b>
	Function( <i>location:Length1Type</i> )	1
<b>LocationPosition</b> ( <i>epc:PositionType</i> )		<b>0-1</b>
	<b>Latitude</b> ( <i>epc:LatitudeType</i> )	<b>1</b>
	<b>Longitude</b> ( <i>epc:LongitudeType</i> )	<b>1</b>
<b>LocationAreas</b> ( <i>location:CGDReferenceKeyType</i> )		<b>0-10</b>
	<b>ReferenceKey</b> ( <i>epc:token</i> )	<b>1</b>
<b>AlternativeLocationNames</b> ( <i>location:AlternativeLocationNamesType</i> )		<b>0-1</b>
<b>LocName1</b> ( <i>location:LocationNamesType</i> )		<b>0-1</b>
	<b>LocName</b> ( <i>location:NameType</i> )	<b>1</b>
	<b>LastUpdateDetails</b> ( <i>location:LastUpdateDetailsType</i> )	<b>1</b>
	<b>LastUpdatedOn</b> ( <i>xs:dateTime</i> )	<b>1</b>
	<b>LastUpdatedBy</b> ( <i>location:CreatedByType</i> )	<b>1</b>
<b>LocName2</b> ( <i>location:LocationNamesType</i> )		<b>0-1</b>
	<b>LocName</b> ( <i>location:NameType</i> )	<b>1</b>
	<b>LastUpdateDetails</b> ( <i>location:LastUpdateDetailsType</i> )	<b>1</b>
	<b>LastUpdatedOn</b> ( <i>xs:dateTime</i> )	<b>1</b>
	<b>LastUpdatedBy</b> ( <i>location:CreatedByType</i> )	<b>1</b>

MS2SSN_Location_Not Elements		Attributes	Occ
<b>LocName3</b> (location:LocationNamesType)			<b>0-1</b>
	<b>LocName</b> (location:NameType)		<b>1</b>
	<b>LastUpdateDetails</b> (location>LastUpdateDetailsType)		<b>1</b>
		<b>LastUpdatedOn</b> (xs:dateTime)	<b>1</b>
		<b>LastUpdatedBy</b> (location:CreatedByType )	<b>1</b>
<b>LocName4</b> (location:LocationNamesType)			<b>0-1</b>
	<b>LocName</b> (location:NameType)		<b>1</b>
	<b>LastUpdateDetails</b> (location>LastUpdateDetailsType)		<b>1</b>
		<b>LastUpdatedOn</b> (xs:dateTime)	<b>1</b>
		<b>LastUpdatedBy</b> (location:CreatedByType )	<b>1</b>
<b>PortFacility</b> (location:PortFacilityType)			<b>0-500</b>
<b>UNECESubsiaryLocation</b> (epc:UNLoCodeContentType)			<b>0-1</b>
<b>PortFacilityDetails</b> (location:PortFacilityDetailsType)			<b>0-1</b>
		<b>Name</b> (epc:string)	<b>1</b>
		<b>Description</b> (epc:string)	<b>1</b>
		<b>LoCode</b> (location:LoCodeType)	<b>1</b>
		<b>GISISCode</b> (location:GisisType)	<b>1</b>
		<b>Position</b> (epc:PositionType)	<b>0-1</b>
		<b>Latitude</b> (epc:LatitudeType)	<b>1</b>
		<b>Longitude</b> (epc:LongitudeType)	<b>1</b>
<b>LastUpdateDetails</b> (location>LastUpdateDetailsType)			<b>1</b>
		<b>LastUpdatedOn</b> (xs:dateTime)	<b>1</b>
		<b>LastUpdatedBy</b> (location:CreatedByType )	<b>1</b>
<b>SSNSubsiaryLocations</b> (location:SSNSubsiaryLocationsType)			<b>0-99</b>
<b>LoCode</b> (epc:UNLoCodeContentType)			<b>1</b>
<b>LastUpdateDetails</b> (LastUpdateDetailsType)			<b>1</b>
		<b>LastUpdatedOn</b> (xs:dateTime)	<b>1</b>
		<b>LastUpdatedBy</b> (location:CreatedByType )	<b>1</b>
<b>InSeca</b> (epc:YesNoEnumType)			<b>0-1</b>
<b>LocationAttributes</b> (location:LocationAttributesType)			<b>0-1</b>
		Bip (epc:YesNoEnumType)	1
		TranshipmentPort (epc:YesNoEnumType)	1
<b>LocationNotificationStatus</b> (location: LocationNotificationStatusType)			<b>1</b>
	<b>RecordUpdateStatus</b> (xs:string)		<b>1</b>
	<b>Digit5LoCode</b> (location:Digit5LoCodeType)		<b>1</b>
		<b>LoCode</b> (location:ExactLoCodeType)	<b>1</b>

### 3.4.3.2 Business rules

The detailed definition of the attributes/ simple types as well as business rules concerning the syntax and business validation of simple types/ attributes is included in Annex B. The following table provides additional business rules concerning data elements/ attributes included in the message

No	MS2SSN_Location_Not Element or Attribute	Action
1	LoCode	Must be unique in CLD database
2	Country	Country code defined by the Central Country Database

### 3.4.3.3 Example

Example of an XML message:

```
<soapenv:Envelope xmlns:soapenv="http://www.w3.org/2003/05/soap-envelope"
xmlns:urn="urn:eu.emsa.ssn.location" xmlns:ns="http://www.iso.org/28005-2">
  <soapenv:Header/>
  <soapenv:Body>
    <urn:MS2SSN_Location_Not>
      <urn:Header From="GRPIR01" SentAt="2017-02-14T10:00:00Z" TestId="b" To="SSN" Version="1.0"/>
      <urn:Body>
        <urn:LocationNotificationDetails>
          <urn:LocationNameWithDiacritics>test_loc_2</urn:LocationNameWithDiacritics>
          <urn:LocationNameWithoutDiacritics>test loc 2</urn:LocationNameWithoutDiacritics>
          <urn:CountryCode>GR</urn:CountryCode>
          <urn:Type>0</urn:Type>
          <urn:FunctionsUNECE Function="1"/>
          <urn:FunctionsUNECE Function="2"/>
          <urn:LocationAreas ReferenceKey="KEY-1"/>
          <urn:LocationAreas ReferenceKey="KEY-2"/>
          <urn:AlternativeLocationNames>
            <urn:LocName1>
              <urn:LocName>test location 2</urn:LocName>
              <urn:LastUpdateDetails>
                <urn:LastUpdatedOn>2017-02-14T10:00:00Z</urn:LastUpdatedOn>
                <urn:LastUpdatedBy>GRPIR01</urn:LastUpdatedBy>
              </urn:LastUpdateDetails>
            </urn:LocName1>
          </urn:AlternativeLocationNames>
          <urn:PortFacility>
            <urn:PortFacilityDetails>
              <urn:Name>name</urn:Name>
              <urn:Description>desc</urn:Description>
              <urn:LoCode>GRXX</urn:LoCode>
              <urn:GISISCode>0002</urn:GISISCode>
              <urn:Position>
                <ns:Latitude>45</ns:Latitude>
                <ns:Longitude>90</ns:Longitude>
              </urn:Position>
            </urn:PortFacilityDetails>
            <urn:LastUpdateDetails>
              <urn:LastUpdatedOn>2017-02-14T10:00:00Z</urn:LastUpdatedOn>
              <urn:LastUpdatedBy>GRPIR01</urn:LastUpdatedBy>
            </urn:LastUpdateDetails>
          </urn:PortFacility>
          <urn:SSNSubsiaryLocations>
            <urn:LoCode>XXX</urn:LoCode>
            <urn:LastUpdateDetails>
              <urn:LastUpdatedOn>2017-02-14T10:00:00Z</urn:LastUpdatedOn>
              <urn:LastUpdatedBy>GRPIR01</urn:LastUpdatedBy>
            </urn:LastUpdateDetails>
          </urn:SSNSubsiaryLocations>
          <urn:InSeca>Y</urn:InSeca>
        </urn:Body>
      </urn:MS2SSN_Location_Not>
    </soapenv:Body>
  </soapenv:Envelope>
```

```

        <urn:LocationAttributes Bip="Y" TranshipmentPort="Y"/>
        <urn:LocationNotificationStatus>
            <urn:RecordUpdateStatus>UPDATED</urn:RecordUpdateStatus>
            <urn:Digit5LoCode>
                <urn:LoCode>GRXXX</urn:LoCode>
            </urn:Digit5LoCode>
        </urn:LocationNotificationStatus>
    </urn:LocationNotificationDetails>
</urn:Body>
</urn:MS2SSN_Location_Not>
</soapenv:Body>
</soapenv:Envelope>
    
```

## 3.5 SSN Receipt Message

### 3.5.1 Introduction

The SSN\_Receipt message is sent by CLD as the confirmation message to every notification (**MS2SSN\_Location\_Not**) or subscription (**MS2SSN\_LocationAnn\_Req**) message from an External System that the message has been successfully validated and processed.

- The SSN\_Receipt message Status Code will be 'OK' if the message has been successfully validated based on applicable business rules and processed.
- The SSN\_Receipt message Status Code will be 'InvalidFormat' if the message is invalid based on applicable business rules.  
 The SSN\_Receipt message Status Code will be 'AccessDenied' if the message is coming from the system which does not have required permissions, or which does not exist in the IdM V2.

### 3.5.2 Message flow

The following figure illustrates the cases when this message must be sent:

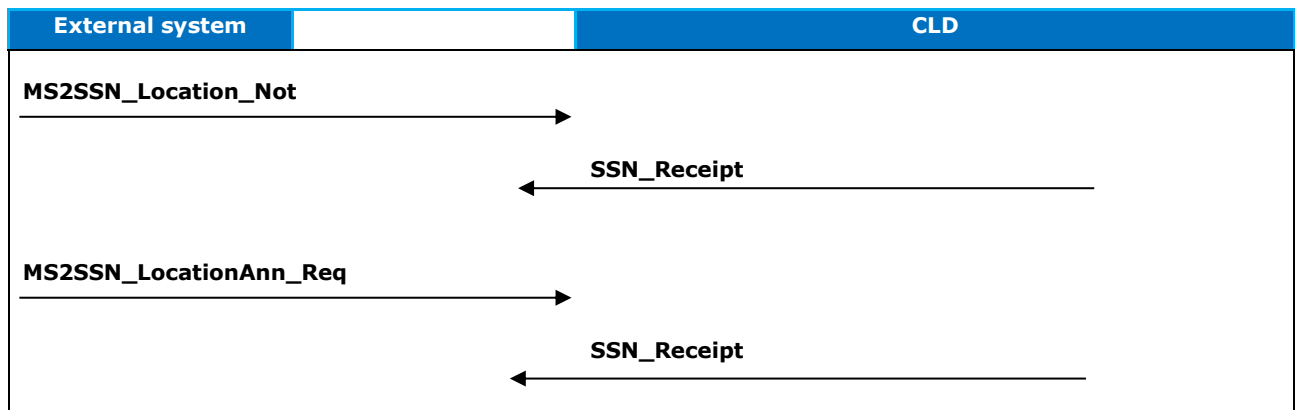

### 3.5.3 SSN\_Receipt.xml message

#### 3.5.3.1 Message description

SSN_Receipt Elements	Attributes	Occ
<b>Header</b> (ssn:Header1Type)		<b>1</b>
	Version	1

SSN_Receipt Elements	Attributes	Occ
	TestId	0-1
	SentAt	1
	From	1
	To	1
	StatusCode	1
	StatusMessage	0-1

### 3.5.3.2 Business rules

The following table describes the XML message used for the transaction and the applicable business rules. The detailed definition of the attributes is included in the Annex B of this document.

Ref	Item (element or sub-element or specific attribute)	Description
1	<b>SentAt</b>	Format "YYYY-MM-DDThh:mm:ssTZD" Where TZD = time zone designator (Z or +hh:mm or -hh:mm).

### 3.5.3.3 Example

Example of SSN Receipt sent to confirm the receipt of a Subscription request.

```
<S:Envelope xmlns:env="http://www.w3.org/2003/05/soap-envelope" xmlns:S="http://www.w3.org/2003/05/soap-envelope">
  <env:Header/>
  <S:Body>
    <ns0:SSN_Receipt xmlns="http://www.iso.org/28005-2" xmlns:ns0="urn:eu.emsa.ssn.location">
      <ns0:Header Version="1.0" TestId="b" SentAt="2019-01-21T08:33:05.273Z" From="SSN" To="GRPIR01"
      StatusCode="OK" StatusMessage="The message processed successfully."/>
    </ns0:SSN_Receipt>
  </S:Body>
</S:Envelope>
```

## 3.6 Status Codes and Status Messages

### 3.6.1 Introduction

Every response or receipt message includes a status code with an optional status message. They are used to provide the result of the processing of a message by CLD or by the External System.

### 3.6.2 Status codes

A status code is provided in every response or receipt message in the *StatusCode* attribute of the *Header* element. It may have one of the following values:

Attribute value	Description
InvalidFormat	The message was not valid

---

Attribute value	Description
NotAvailable	The message has not been processed because the CGD was not available.
ServerError	The message has not been successfully processed due to a server problem (e.g. connection problem, database problem, application problem).
OK	The message has been successfully received or the information requested in the corresponding request message has been found (response messages).
NotFound	The information requested in the request message does not exist. This value may only be used by CLD in a response message. This value is not available for MS2SSNmessages
AccessDenied	The user account (identified via the <i>From</i> attribute of the <i>Header</i> element) is not allowed to send the message or does not exist.

### 3.6.3 Status messages

Next to the *StatusCode* attribute, a corresponding *StatusMessage* attribute is always provided and may be used to provide additional details regarding the status code.

The status message should be provided in the English language, as it is used for debugging.

Please refer to the description of the XML messages for more details.



## ANNEX A - DESCRIPTION OF CLD LOCATION WEB-SERVICE

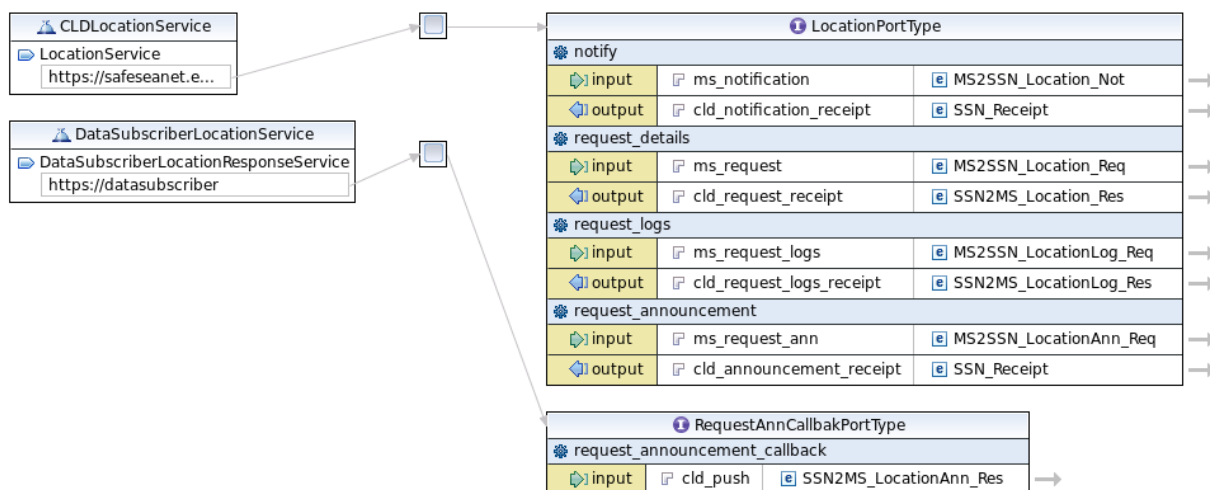

Figure 5: CLD Location web service

## ANNEX B – ATTRIBUTES AND SIMPLE TYPE DEFINITIONS

Attribute/Element (simple type) name	Data Type	Len	Description and general rules	Message(s) that the attribute/ simple type is included
AnnouncementUrl xsd: (anyURI)	Text	1-256	The URL of the subscriber SOAP node receives the CLD announcements; HTTP(S) protocol.	MS2SSN_LocationAnn_Req
ApplicationName	Text	1-10	The code/acronym of the application exchanging data with CLD.	MS2SSN_LocationAnn_Req
ApplicationNameUsingLocation	Text	1-10	The code/acronym of the application exchanging data with CLD. Value equal to ApplicationName	SSN2MS_Location_Res SSN2MS_LocationLog_Res SSN2MS_LocationAnn_Res
Category (defined within "LocationAreas" element)	Text	1-256	Category of a geographical area defined in the EMSA Central Geo-reference Database (CGD). Refer to the Annex D for the applicable Area Category codes	SSN2MS_Location_Res SSN2MS_LocationLog_Res SSN2MS_LocationAnn_Res
Comments	Text	1-256	Any additional information regarding the location.	MS2SSN_Location_Not SSN2MS_Location_Res SSN2MS_LocationAnn_Res SSN2MS_LocationLog_Res

Attribute/Element (simple type) name	Data Type	Len	Description and general rules	Message(s) that the attribute/ simple type is included
CountryCode	Text	2	Two-characters Country code of a Country is registered into the Central Country Database – CCD maintained by EMSA).  Accepted values are those associated with standard political entity: Alpha-2 (two-characters) in accordance with standard ISO 3166-1) of the Country as well as the following codes assigned to virtual counties:  EU – for “European Commission”  XZ – for “Installations in international waters”	MS2SSN_Location_Not MS2SSN_Location_Req SSN2MS_Location_Res MS2SSN_LocationAnn_Req SSN2MS_LocationAnn_Res SSN2MS_LocationLog_Res
CreatedBy (location:CreatedByType)	Text	1-32	A valid SSN unique user Identifier. of the user who created a location in the CLD	SSN2MS_Location_Res SSN2MS_LocationAnn_Res SSN2MS_LocationLog_Res
CreatedOn (xsd:dateTime)	DT		Date and time of the creation of a location in the CLD	SSN2MS_Location_Res SSN2MS_LocationAnn_Res SSN2MS_LocationLog_Res
Description (defined within element “PortFacilityDetails”)	Text	1-255	Facility description in GISIS Maritime Security	MS2SSN_Location_Not SSN2MS_Location_Res SSN2MS_LocationAnn_Res SSN2MS_LocationLog_Res
Description (defined within “LocationAreas” element)	Text	1-256	Textual description of the area	SSN2MS_Location_Res SSN2MS_LocationLog_Res SSN2MS_LocationAnn_Res

Attribute/Element (simple type) name	Data Type	Len	Description and general rules	Message(s) that the attribute/ simple type is included
EncodeListYesOrNo	Enum		Possible values:Y or N	MS2SSN_Location_Req
EndTime (xs:dateTime)	DT		Ending point of a time window declared to define a query	MS2SSN_LocationAnn_Req
ESRefId (location:ESRefIdType)	Text	1-36	Reference identifier specified by the original announcement subscriber request.	MS2SSN_LocationAnn_Req SSN2MS_LocationAnn_Res
From	Text	7-32	The UserID of the system user despatching a message (as defined in SafeSeaNet). Best practice for the field is to include the reference identification of the originator of the data included in the message	MS2SSN_Location_Not MS2SSN_Location_Req SSN2MS_Location_Res MS2SSN_LocationAnn_Req SSN2MS_LocationAnn_Res MS2SSN_LocationLog_Req SSN2MS_LocationLog_Res SSN_Receipt
Function	Text	1	Function number (classifier code) as defined by UNECE. Mandatory for UNECE locations.	MS2SSN_Location_Not SSN2MS_Location_Res SSN2MS_LocationAnn_Res SSN2MS_LocationLog_Res

Attribute/Element (simple type) name	Data Type	Len	Description and general rules	Message(s) that the attribute/ simple type is included
GISIScode	Text	4	The GISIS code field is a four-digit string corresponding to the port facility's code in the IMO GISIS maritime security database	MS2SSN_Location_Not MS2SSN_Location_Req SSN2MS_Location_Res MS2SSN_LocationAnn_Req SSN2MS_LocationAnn_Res SSN2MS_LocationLog_Res
InEU	Enum		Indicates whether the location is in the EU. This is used for EU locations not associated to an actual country (e.g. XZ) Possible values:Y or N	SSN2MS_Location_Res SSN2MS_LocationAnn_Res SSN2MS_LocationLog_Res
InSeca	Enum		Whether the location is in a Sulphur Emission Control Area (SECA). Possible values:Y or N	MS2SSN_Location_Not SSN2MS_Location_Res SSN2MS_LocationAnn_Res SSN2MS_LocationLog_Res
LastUpdatedBy	Text	1-32	A valid SSN unique user Identifier of the user who last updated a location in the CLD	MS2SSN_Location_Not SSN2MS_Location_Res SSN2MS_LocationAnn_Res SSN2MS_LocationLog_Res
LastUpdatedOn (xsd:dateTime)	DT		Date and time of the last update of an organisation in the CLD	MS2SSN_Location_Not SSN2MS_Location_Res SSN2MS_LocationAnn_Res SSN2MS_LocationLog_Res

Attribute/Element (simple type) name	Data Type	Len	Description and general rules	Message(s) that the attribute/ simple type is included
Latitude	Decimal		Latitude in decimal degrees	MS2SSN_Location_Not SSN2MS_Location_Res SSN2MS_LocationAnn_Res SSN2MS_LocationLog_Res
LocationNameWithDiacritics	Text	1-50	Official name of the location with diacritics. Equals to the Name with diacritics provided by UNECE for UNECE locations (e.g. Zákynthos for Locode GRZTH)	MS2SSN_Location_Not SSN2MS_Location_Res SSN2MS_LocationAnn_Res SSN2MS_LocationLog_Res
LocationNameWithoutDiacritics	Text	1-50	Name of the location without diacritics. Equals to the Name without diacritics provided by UNECE for UNECE locations (e.g. Zakynthos for Locode GRZTH).	MS2SSN_Location_Not SSN2MS_Location_Res SSN2MS_LocationAnn_Res SSN2MS_LocationLog_Res
LocName	Text	1-50	Alternative location name (e.g. Zante for Locode GRZTH)	MS2SSN_Location_Not SSN2MS_Location_Res SSN2MS_LocationAnn_Res SSN2MS_LocationLog_Res

Attribute/Element (simple type) name	Data Type	Len	Description and general rules	Message(s) that the attribute/ simple type is included
LoCode	Text	5	<p>Unique identifier of the location (concatenation of the 2-character ISO code of a country and a 3-character unique location identifier as defined by UNECE and/or in SSN.</p> <p><b>Note:</b> SSN specific locodes in the form [Countrycode_888] (e.g.PT888) are used in the context of CLD to identify an unknown port in a given country</p>	<p>MS2SSN_Location_Not SSN2MS_Location_Res SSN2MS_LocationAnn_Res SSN2MS_LocationLog_Res</p>
Longitude	Decimal		Longitude in decimal degrees	<p>MS2SSN_Location_Not SSN2MS_Location_Res SSN2MS_LocationAnn_Res SSN2MS_LocationLog_Res</p>
Name (defined within element "PortFacilityDetails")	Text	1-Undefined	Name of a port, written as the port name is normally written.	<p>MS2SSN_Location_Not SSN2MS_Location_Res SSN2MS_LocationAnn_Res SSN2MS_LocationLog_Res</p>
Name (defined within "LocationAreas" element)	Text	1-50	The Name of a duty Area defined in COD	<p>SSN2MS_Location_Res SSN2MS_LocationLog_Res SSN2MS_LocationAnn_Res</p>

Attribute/Element (simple type) name	Data Type	Len	Description and general rules	Message(s) that the attribute/ simple type is included
RecordUpdateStatus	Text	1-Undefined	Informative Field identifying if MS2SSN_Location_Not is a new notification sent by the data provider (in order to create a new location into the CLD) or if the notification is sent in order to update previously provided data.  <b>Note:</b> In the present release no validation is executed in relation to this field and there no processing rules associated to the notification status reported by the field.	MS2SSN_Location_Not
ReferenceKey	Text	1-256	<i>Reference key of a geographical area defined in the EMSA Central Geo-reference Database (CGD)</i>	MS2SSN_Location_Not SSN2MS_Location_Res SSN2MS_LocationAnn_Res SSN2MS_LocationLog_Res
Searchby5digitLoCode	Text	5	Unique identifier of the location (concatenation of the 2-character ISO code of a country and a 3-character unique location identifier as defined by UNECE and/or in SSN).  <b>Note:</b> SSN specific locodes in the form [Countrycode_888] (e.g.PT888) are used in the context of CLD to identify an unknown port in a given country	MS2SSN_Location_Req MS2SSN_LocationLog_Req
SearchByApplicationCode	Text	1-10	Search criterion for the locations currently active in the maritime application specified by the application code/acronym.	MS2SSN_Location_Req
SearchByBip	Enum		Possible values: Y or N	MS2SSN_Location_Req



Attribute/Element (simple type) name	Data Type	Len	Description and general rules	Message(s) that the attribute/ simple type is included
SearchByLocode	Text	1-5	Search criterion for the locations for which the LoCode contains a pattern match of the input string.	MS2SSN_Location_Req
SearchByName	Text	1-50	Search criterion for the locations for which the name with diacritics, or the name without diacritics, or any of the other location names, contains a pattern match of the input string.	MS2SSN_Location_Req
SearchByTransshipment	Enum		Possible values: Y or N	MS2SSN_Location_Req
SentAt	DT		Date and time the message was sent. If local time is used ES application has to adjust the time to UTC.  Format "YYYY-MM-DDThh:mm:ssTZD"  Where TZD = time zone designator (Z or +hh:mm or -hh:mm).	MS2SSN_Location_Not MS2SSN_Location_Req SSN2MS_Location_Res MS2SSN_LocationAnn_Req SSN2MS_LocationAnn_Res MS2SSN_LocationLog_Req SSN2MS_LocationLog_Res SSN_Receipt
SSNRefId	Text	1-36	Reference id given by CLD in Announcement messages.	SSN2MS_LocationAnn_Res
StartDateTime	DT		Starting point of a time window declared to define a query	MS2SSN_Location_Req MS2SSN_LocationAnn_Req MS2SSN_LocationLog_Req
Status	Enum		Indicates whether the location is active in the CLD.  Possible values:Y or N	SSN2MS_Location_Res SSN2MS_LocationAnn_Res SSN2MS_LocationLog_Res

Attribute/Element (simple type) name	Data Type	Len	Description and general rules	Message(s) that the attribute/ simple type is included
StatusCode	ENUM		Global status code, refer to section 0	SSN2MS_Location_Res SSN2MS_LocationAnn_Res SSN2MS_LocationLog_Res SSN_Receipt
StatusMessage (xs:string)	Text	0-255	Global status message string. Refer to section 3.6.3.	SSN2MS_Location_Res SSN2MS_LocationAnn_Res SSN2MS_LocationLog_Res SSN_Receipt
TestId (xs:string)	Text	0-8	Test Case identification. Only useful for testing	MS2SSN_Location_Not MS2SSN_Location_Req SSN2MS_Location_Res MS2SSN_LocationAnn_Req SSN2MS_LocationAnn_Res MS2SSN_LocationLog_Req SSN2MS_LocationLog_Res SSN_Receipt

Attribute/Element (simple type) name	Data Type	Len	Description and general rules	Message(s) that the attribute/ simple type is included
To	Text	7-32	The reference identification of the recipient of a message exchanged	MS2SSN_Location_Not MS2SSN_Location_Req SSN2MS_Location_Res MS2SSN_LocationAnn_Req SSN2MS_LocationAnn_Res MS2SSN_LocationLog_Req SSN2MS_LocationLog_Res SSN_Receipt
Type	Enum		Type of the location (e.g. SSN specific, UNECE). Possible values:0 or 1	SSN2MS_Location_Res SSN2MS_LocationAnn_Res SSN2MS_LocationLog_Res
UNECESubsidiaryLocation	Text	3	Subsidiary location within the port or port approaches (e.g. a terminal in the port, a berth, an anchorage site, a fairway section etc) as defined in UNECE recommendation 16	MS2SSN_Location_Not SSN2MS_Location_Res SSN2MS_LocationAnn_Res SSN2MS_LocationLog_Res
UNLoCode	Text	3	Three-letter location code as defined in UNECE R16. The location code (lower case) "xxx" is reserved for an unknown location code.	MS2SSN_Location_Not SSN2MS_Location_Res SSN2MS_LocationAnn_Res SSN2MS_LocationLog_Res

Attribute/Element (simple type) name	Data Type	Len	Description and general rules	Message(s) that the attribute/ simple type is included
Version (xs:string)	Text	3	CLD web services curent version ('x.x')	MS2SSN_Location_Not MS2SSN_Location_Req SSN2MS_Location_Res MS2SSN_LocationAnn_Req SSN2MS_LocationAnn_Res MS2SSN_LocationLog_Req SSN2MS_LocationLog_Res SSN_Receipt
ZippedLocationListInBase64	Base64		Base64 encoded content including a list of locations. For each of the location the list reports the attributes foreseen in the LocationDetails ELEMENT foreseen in the structure of the SSN2MS_Location_Res	SSN2MS_Location_Res

---

## ANNEX C– LIST OF APPLICATION CODES (INDICATIVE)

---

The list below provides the list of application codes maintained in the CLD. Additional applications may be defined in the future, if need will arise.

Application Code	Application Name	Description
CLD	Central Location Database	The CLD includes all LOCODEs listed in the UN/LOCODE list and SSN Specific locations, as well as port facilities information stemming from the IMO Maritime Security module of the Global Integrated Shipping Information System (GISIS).
SSN	SafeSeaNet	<p>Only UN/LOCODEs with functions 1 and 7 (if confirmed by a reliable source as being an off-shore installation) and SSN specific locations as well as port facilities information stemming from the IMO Maritime Security module of the Global Integrated Shipping Information System (GISIS), are assigned to SSN application in the CLD.</p> <p>The LOCODEs assigned to SSN application code are stored in the SSN operational locode registry and they should be used by the National SSN systems.</p>